

**PMI2-TC**

**PMI2-TL**

**Rev. A+  
Mainboard  
User's Manual**

## Copyright

This publication contains information that is protected by copyright. No part of it may be reproduced in any form or by any means or used to make any transformation/adaptation without the prior written permission from the copyright holders.

This publication is provided for informational purposes only. The manufacturer makes no representations or warranties with respect to the contents or use of this manual and specifically disclaims any express or implied warranties of merchantability or fitness for any particular purpose. The user will assume the entire risk of the use or the results of the use of this document. Further, the manufacturer reserves the right to revise this publication and make changes to its contents at any time, without obligation to notify any person or entity of such revisions or changes.

© 2002. All Rights Reserved.

## Trademarks

Windows® 98, Windows® 98 SE, Windows® ME, Windows® 2000, Windows NT® 4.0 and Windows® XP are registered trademarks of Microsoft Corporation. Intel® and Pentium® 4 are registered trademarks of Intel Corporation. VIA is a registered trademark of VIA Technologies, Inc. Award is a registered trademark of Award Software, Inc. Other trademarks and registered trademarks of products appearing in this manual are the properties of their respective holders.

## Caution

To avoid damage to the system:

- Use the correct AC input voltage range.

To reduce the risk of electric shock:

- Unplug the power cord before removing the system chassis cover for installation or servicing. After installation or servicing, cover the system chassis before plugging the power cord.

Battery:

- Danger of explosion if battery incorrectly replaced.
- Replace only with the same or equivalent type recommend by the manufacturer.
- Dispose of used batteries according to the battery manufacturer's instructions.

Joystick or MIDI port:

- Do not use any joystick or MIDI device that requires more than 10A current at 5V DC. There is a risk of fire for devices that exceed this limit.

## **FCC and DOC Statement on Class B**

This equipment has been tested and found to comply with the limits for a Class B digital device, pursuant to Part 15 of the FCC rules. These limits are designed to provide reasonable protection against harmful interference when the equipment is operated in a residential installation. This equipment generates, uses and can radiate radio frequency energy and, if not installed and used in accordance with the instruction manual, may cause harmful interference to radio communications. However, there is no guarantee that interference will not occur in a particular installation. If this equipment does cause harmful interference to radio or television reception, which can be determined by turning the equipment off and on, the user is encouraged to try to correct the interference by one or more of the following measures:

- Reorient or relocate the receiving antenna.
- Increase the separation between the equipment and the receiver.
- Connect the equipment into an outlet on a circuit different from that to which the receiver is connected.
- Consult the dealer or an experienced radio TV technician for help.

Notice:

1. The changes or modifications not expressly approved by the party responsible for compliance could void the user's authority to operate the equipment.
2. Shielded interface cables must be used in order to comply with the emission limits.

## Notice

This user's manual contains detailed information about the mainboard. If, in some cases, some information doesn't match those shown in the multilingual manual, the multilingual manual should always be regarded as the most updated version. The multilingual manual is included in the mainboard package.

To view the user's manual, insert the CD into a CD-ROM drive. The autorun screen (Mainboard Utility CD) will appear: Click the "Tools" icon then click "Manual" on the main menu.

## Mainboard

This user's manual is for the PM12-TC and PM12-TL mainboards. The only difference between these boards is the PM12-TL mainboard supports onboard LAN.

# Table of Contents

## Chapter 1 - Introduction

1.1 Features and Specifications.....	7
1.2 Package Checklist.....	14

## Chapter 2 - Hardware Installation

2.1 Mainboard Layout .....	15
2.2 System Memory.....	17
2.3 Jumper Settings for Clearing CMOS Data.....	19
2.4 Jumper Settings for Selecting the CPU's Front Side Bus.....	21
2.5 Jumper Settings for Selecting the PS/2 Power.....	22
2.6 Rear Panel I/O Ports.....	23
2.7 I/O Connectors.....	34

## Chapter 3 - Award BIOS Setup Utility

3.1 The Basic Input/Output System.....	48
3.1.1 Standard CMOS Features.....	48
3.1.2 Advanced BIOS Features.....	53
3.1.3 Advanced Chipset Features .....	57
3.1.4 Integrated Peripherals.....	64
3.1.5 Power Management Setup.....	71
3.1.6 PnP/PCI Configurations.....	78
3.1.7 Frequency/Voltage Control.....	81
3.1.8 Load Fail-Safe Defaults.....	83
3.1.9 Load Optimized Defaults.....	83
3.1.10 Set Supervisor Password.....	84
3.1.11 Set User Password.....	84
3.1.12 Save & Exit Setup.....	85
3.1.13 Exit Without Saving.....	85
3.2 Updating the BIOS.....	86

## Chapter 4 - Supported Softwares

4.1 Desktop Management Interface.....	88
4.2 Drivers, Utilities and Software Applications.....	91
4.3 Installation Notes.....	100

## Appendix A - Using the Suspend to RAM Function

A.1 Using the Suspend to RAM Function.....	101
--	-----

## Appendix B - System Error Messages

B.1 POST Beep.....	105
B.2 Error Messages.....	105

## Appendix C - Troubleshooting

C.1 Troubleshooting Checklist.....	107
------------------------------------	-----

# Chapter I - Introduction

---

## I.I Features and Specifications

### I.I.I Features

#### Chipset

- VIA® P4M266A/VT8235CD

#### Processor

The system board is equipped with Socket 478 for installing one of the following supported processors.

- Intel® Pentium® 4 processor (478-pin)
  - 533MHz system data bus
  - 400MHz system data bus
- Intel® Celeron® processor (478-pin)
  - 400MHz system data bus

#### System Memory

- Two 184-pin DDR DIMM sockets
- Supports up to 2GB using PC1600 (DDR200) or PC2100 (DDR266) unbuffered DDR SDRAM DIMM, 2.5V type
- Uses x8/x16 512MB technology

DIMMs	Memory Size	DIMMs	Memory Size
2MBx64	16MB	16MBx64	128MB
4MBx64	32MB	32MBx64	256MB
8MBx64	64MB	64MBx64	512MB

### Expansion Slots

The mainboard is equipped with 1 universal AGP slot and 3 PCI slots.

AGP is an interface designed to support high performance 3D graphics cards. It utilizes a dedicated pipeline to access system memory for texturing, z-buffering and alpha blending. The universal AGP slot supports AGP 2x with up to 533MB/sec. bandwidth and AGP 4x with up to 1066MB/sec. bandwidth for 3D graphics applications. AGP in this mainboard will deliver faster and better graphics to your PC.

### Onboard Audio Features

- Supports Microsoft® DirectSound/DirectSound 3D
- AC'97 supported with full duplex, independent sample rate converter for audio recording and playback

### Onboard LAN Features (PM12-TL only)

- Integrated LAN controller
- Integrated IEEE 802.3, 10BASE-T and 100BASE-TX compatible PHY
- 32-bit PCI master interface
- Integrated power management functions
- Full duplex support at both 10 and 100 Mbps
- Supports IEEE 802.3u auto-negotiation
- Supports wire for management

### Onboard Graphics Features

- Full featured Accelerated Graphics Port (AGP) controller
  - AGP specification v2.0 compliant
  - Graphics Address Relocation Table (GART)
- High resolution CRT RGB interface
  - 250MHz RAMDAC on chip with Gamma correction
  - Horizontal/vertical sync outputs compliant with Monitor Power Management protocols
- Integrated Savage8 2D/3D graphics controller and video accelerator
  - Optimized Shared Memory Architecture (SMA)
  - 8/16/32MB frame buffer using system memory



- Single cycle 128-bit 3D architecture
- 8M triangles/second setup engine
- 140M pixels/second tri-linear fill rate
- Next generation 128-bit 2D graphics engine
- High quality DVD video playback
- 2D/3D resolutions up to 1920x1440
- 3D rendering features
  - MPEG-2 video textures
- 2D hardware acceleration features
- Motion video architecture
- Full software support

### PCI Bus Master IDE Controller

- Two PCI IDE interfaces support up to four IDE devices
- Supports ATA/33, ATA/66, ATA/100 and ATA/133 hard drives
- UDMA Modes 3, 4, 5 and 6 Enhanced IDE (data transfer rate up to 133MB/sec.)
- Bus mastering reduces CPU utilization during disk transfer
- Supports ATAPI CD-ROM, LS-120 and ZIP

### IrDA Interface

The mainboard is equipped with an IrDA connector for wireless connectivity between your computer and peripheral devices.

### USB Ports

The mainboard supports 4 USB 2.0 (compliant with USB 1.1) ports. USB 1.1 supports 12Mb/second bandwidth while USB 2.0 supports 480Mb/second bandwidth providing a marked improvement in device transfer speeds between your computer and a wide range of simultaneously accessible external Plug and Play peripherals.

### BIOS

- Award BIOS, Windows® 98/2000/ME/XP Plug and Play compatible
- Supports SCSI sequential boot-up
- Flash EPROM for easy BIOS upgrades
- Supports DMI 2.0 function
- 2Mbit flash memory

### Desktop Management Interface (DMI)

The mainboard comes with a DMI 2.0 built into the BIOS. The DMI utility in the BIOS automatically records various information about your system configuration and stores these information in the DMI pool, which is a part of the system board's Plug and Play BIOS. DMI, along with the appropriately networked software, is designed to make inventory, maintenance and troubleshooting of computer systems easier. Refer to chapter 4 for instructions on using the DMI utility.

### Rear Panel I/O Ports (PC 99 color-coded connectors)

- Two USB 2.0/1.1 ports
- One RJ45 LAN port (PM12-TL only)
- One DB-9 serial port
- One DB-15 VGA port
- One DB-25 parallel port
- One mini-DIN-6 PS/2 mouse port
- One mini-DIN-6 PS/2 keyboard port
- One game/MIDI port
- Three audio jacks: line-out, line-in and mic-in

### I/O Connectors

- One connector for 2 additional external USB 2.0/1.1 ports
- One connector for 1 external serial port
- One connector for external line-out and mic-in jacks
- Two internal audio connectors (AUX-in and CD-in)
- One connector for IrDA interface
- Two IDE connectors
- One floppy drive interface supports up to two 2.88MB floppy drives
- Two ATX power supply connectors
- One Wake-On-LAN connector
- One Wake-On-Ring connector
- CPU fan and chassis fan connectors

## 1.1.2 Intelligence

### Dual Function Power Button

Depending on the setting in the “Soft-Off By PWRBTN” field of the Power Management Setup, this switch will allow the system to enter the Soft-Off or Suspend mode.

### Wake-On-Ring

This feature allows the system that is in the Suspend mode or Soft Power Off mode to wake-up/power-on to respond to calls coming through an internal or external modem. Refer to “Wake-On-Ring Connector” in chapter 2 and “Resume On LAN/Ring” (“IRQ/Event Activity Detect” field) in the Power Management Setup section in chapter 3 for more information.



**Important:**

*If you are using a modem add-in card, the 5VSB power source of your power supply must support  $\geq 720\text{mA}$ .*

### Wake-On-LAN

The Wake-On-LAN function allows the network to remotely wake up a Soft Power Down (Soft-Off) PC. Your LAN card must support the remote wakeup function. Refer to “Wake-On-LAN Connector” in chapter 2 and “Resume On LAN/Ring” (“IRQ/Event Activity Detect” field) in the Power Management Setup section in chapter 3 for more information.



**Important:**

*The 5VSB power source of your power supply must support  $\geq 720\text{mA}$ .*

### Wake-On-PS/2 Keyboard/Mouse

This function allows you to use the PS/2 keyboard or PS/2 mouse to wake up the system from the S5 state. Refer to “Jumper Settings for Selecting the PS/2 Power” in chapter 2 and “PS2KB Wakeup Select” (“IRQ/Event Activity Detect” field) in the Power Management section in chapter 3 for more information.

**Important:**

- *If you forgot the password, you must power-off the system, unplug the power cord and clear the CMOS data. Follow the steps in the “Jumper Settings for Clearing CMOS Data” section in chapter 2.*
- *The 5VSB power source of your power supply must support  $\geq 720\text{mA}$ .*

### Wake-On-USB Keyboard/Mouse

This function allows you to use a USB keyboard or USB mouse to wake up a system from the S3 (STR - Suspend To RAM) state. Refer to “USB Resume from S3” (“IRQ/Event Activity Detect” field) in the Power Management Setup section in chapter 3 for more information.

**Important:**

- *If you are using the Wake-On-USB Keyboard/Mouse function for 2 USB ports, the 5VSB power source of your power supply must support  $\geq 1.5\text{A}$ .*
- *If you are using the Wake-On-USB Keyboard/Mouse function for 3 or more USB ports, the 5VSB power source of your power supply must support  $\geq 2\text{A}$ .*

### RTC Timer to Power-on the System

The RTC installed on the mainboard allows your system to automatically power-on on the set date and time. Refer to “Resume On Alarm” (“IRQ/Event Activity Detect” field) in the Power Management Setup section in chapter 3 for more information.

## ACPI STR

The mainboard is designed to meet the ACPI (Advanced Configuration and Power Interface) specification. ACPI has energy saving features that enables PCs to implement Power Management and Plug-and-Play with operating systems that support OS Direct Power Management. Currently, only Windows® 98/2000/ME/XP supports the ACPI function. ACPI when enabled in the Power Management Setup will allow you to use the Suspend to RAM function.

With the Suspend to RAM function enabled, you can power-off the system at once by pressing the power button or selecting “Standby” when you shut down Windows® 98/2000/ME/XP without having to go through the sometimes tiresome process of closing files, applications and operating system. This is because the system is capable of storing all programs and data files during the entire operating session into RAM (Random Access Memory) when it powers-off. The operating session will resume exactly where you left off the next time you power-on the system. Refer to “Using the Suspend to RAM Function” in appendix A for more information.



### **Important:**

*The 5VSB power source of your power supply must support  $\geq 1A$ .*

## AC Power Failure Recovery

When power returns after an AC power failure, you may choose to either power-on the system manually, let the system power-on automatically or return to the state where you left off before power failure occurs. Refer to “PWR Lost Resume State” in the Power Management Setup section in chapter 3 for more information.

## Virus Protection

Most viruses today destroy data stored in hard drives. The mainboard is designed to protect the boot sector and partition table of your hard disk drive.

## I.2 Package Checklist

The mainboard package contains the following items:

- The mainboard
- A user's manual
- One card-edge bracket mounted with a serial port
- One IDE cable for ATA/33, ATA/66, ATA/100 or ATA/133 IDE drives
- One 34-pin floppy disk drive cable
- One "Main Board Utility" CD

If any of these items are missing or damaged, please contact your dealer or sales representative for assistance.

# Chapter 2 - Hardware Installation

## 2.1 Mainboard Layout

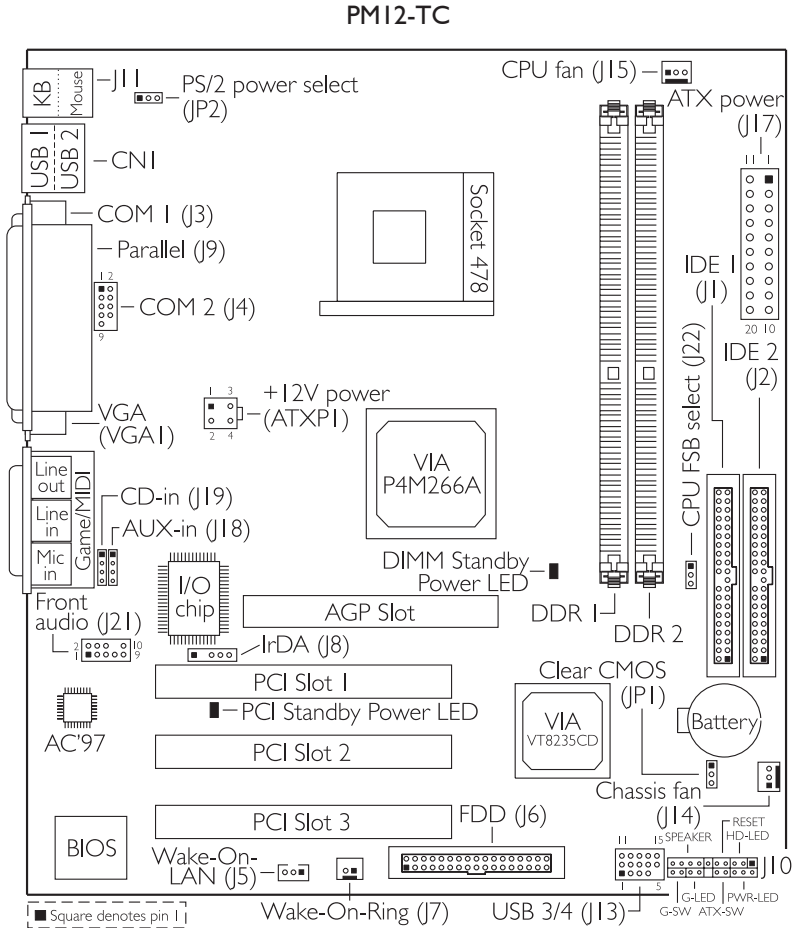

### PM12-TL (Supports onboard LAN)

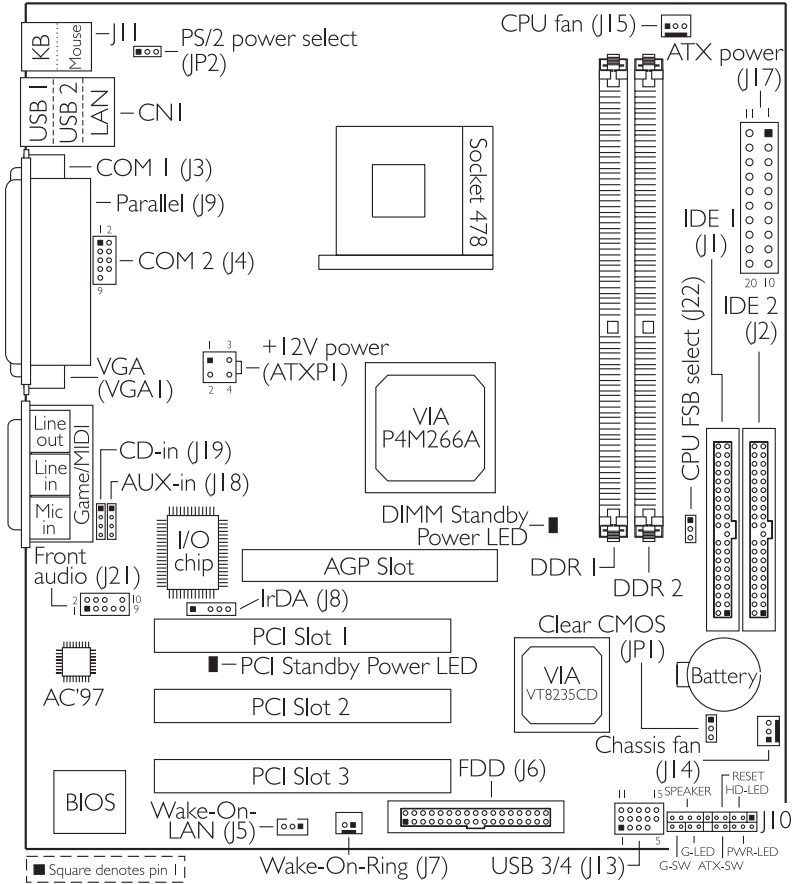

**Note:**

The illustrations on the following pages are based on the mainboard that supports onboard LAN.



**Warning:**

Electrostatic discharge (ESD) can damage your mainboard, processor, disk drives, add-in boards, and other components. Perform the upgrade instruction procedures described at an ESD workstation only. If such a station is not available, you can provide some ESD protection by wearing an antistatic wrist strap and attaching it to a metal part of the system chassis. If a wrist strap is unavailable, establish and maintain contact with the system chassis throughout any procedures requiring ESD protection.

## 2.2 System Memory

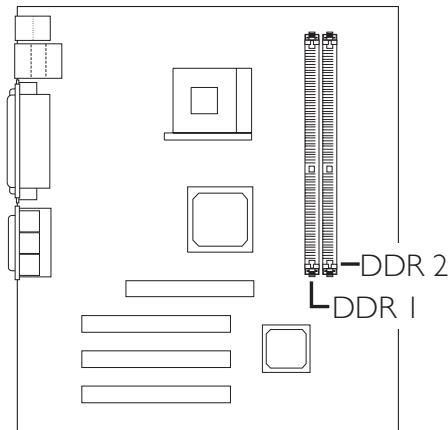

The system board is equipped with two 184-pin DDR SDRAM DIMM (Dual In-line Memory Module) sockets that support 2.5V DDR SDRAM DIMM. Double Data Rate SDRAM (DDR SDRAM) is a type of SDRAM that doubles the data rate through reading and writing at both the rising and falling edge of each clock. This effectively doubles the speed of operation therefore doubling the speed of data transfer.

Refer to chapter 1 (System Memory section) for detailed specification of the memory supported by the system board.

### 2.2.1 Installing the DIM Module

A DIM module simply snaps into a DIMM socket on the system board. Pin 1 of the DIM module must correspond with Pin 1 of the socket.

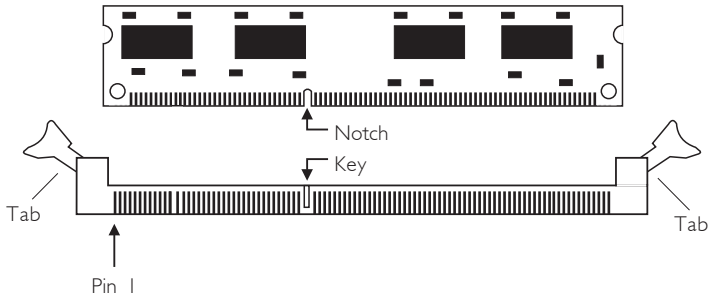

1. Pull the "tabs" which are at the ends of the socket to the side.
2. Position the DIMM above the socket with the "notch" in the module aligned with the "key" on the socket.
3. Seat the module vertically into the socket. Make sure it is completely seated. The tabs will hold the DIMM in place.

## 2.3 Jumper Settings for Clearing CMOS Data

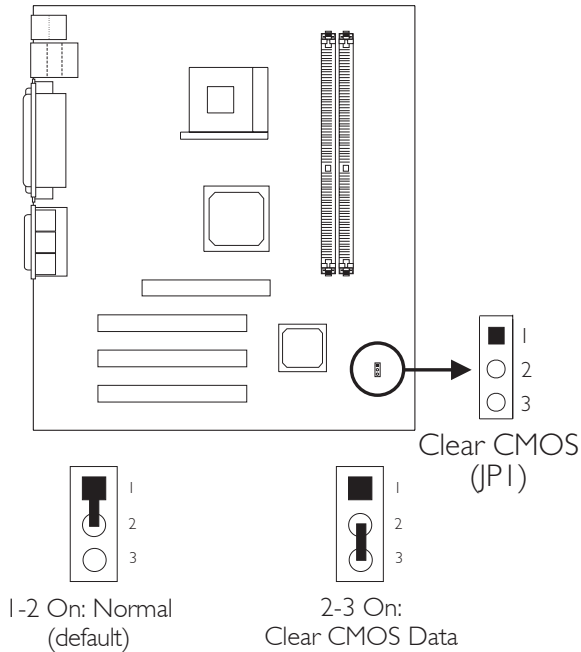

### Clear CMOS Data - Jumper JPI

If you encounter the following,

- CMOS data becomes corrupted.
- You forgot the keyboard, supervisor or user password.
- You are unable to boot-up the computer system because the processor's ratio/clock was incorrectly set in the BIOS.

you can reconfigure the system with the default values stored in the ROM BIOS.

To load the default values stored in the ROM BIOS, please follow the steps below.

- Power-off the system and unplug the power cord.
- Set JPI pins 2 and 3 to On. Wait for a few seconds and set JPI back to its default setting, pins 1 and 2 On.

3. Now power-on the system.

If your reason for clearing the CMOS data is due to incorrect setting of the processor's ratio/clock in the BIOS, please proceed to step 4.

4. After powering-on the system, press <Del> to enter the main menu of the BIOS.
5. Select the Frequency/Voltage Control submenu and press <Enter>.
6. Set the "CPU Clock Ratio" or "CPU Clock" field to its default setting or an appropriate frequency ratio or bus clock. Refer to the Frequency/Voltage Control section in chapter 3 for more information.
7. Press <Esc> to return to the main menu of the BIOS setup utility. Select "Save & Exit Setup" and press <Enter>.
8. Type <Y> and press <Enter>.

## 2.4 Jumper Settings for Selecting the CPU's Front Side Bus

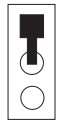
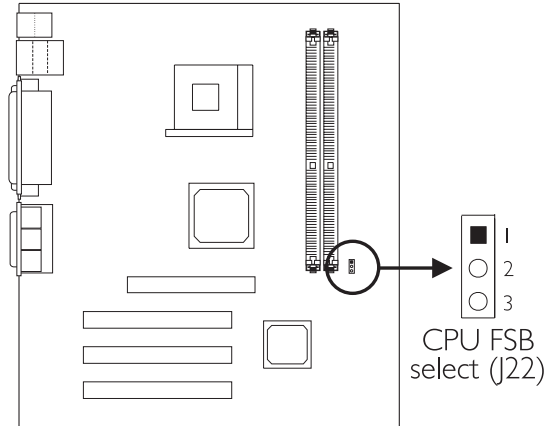

1-2 On: Auto  
(default)

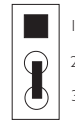

2-3 On:  
100MHz

### CPU Front Side Bus Select - Jumper J22

The default setting of this jumper is Auto. The system will automatically detect the front side bus of the processor installed on the system board. Set J22 pins 2 and 3 to On if you want to set the front side bus to 100MHz.



#### Important:

*Overclocking may result in the processor's or system's instability and is not guaranteed to provide better system performance.*

## 2.5 Jumper Settings for Selecting the PS/2 Power

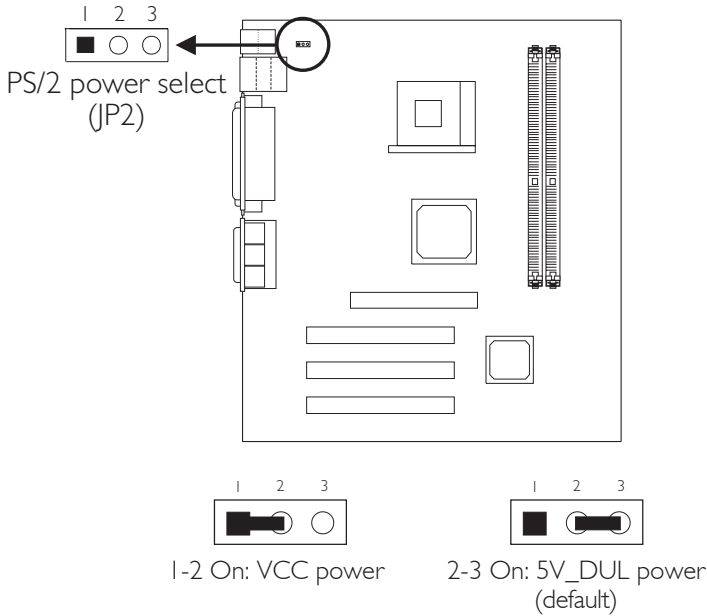

### Power Select for PS/2 Keyboard/Mouse - Jumper JP2

This jumper is used to select the power of the PS/2 keyboard and PS/2 mouse.



**Note:**

*If you wish to use the Wake-On-PS/2 Keyboard function, make sure this jumper is set to "2-3 On". "PS2KB Wakeup Select" ("IRQ/Event Activity Detect" field) in the Power Management submenu of the BIOS must be set accordingly.*

## 2.6 Rear Panel I/O Ports

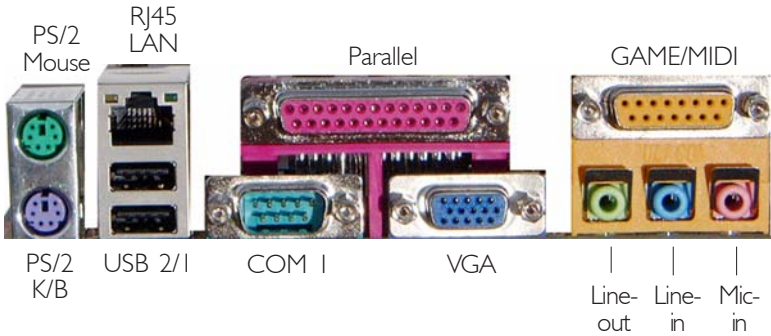

The Rear Panel I/O Ports on PM12-TL

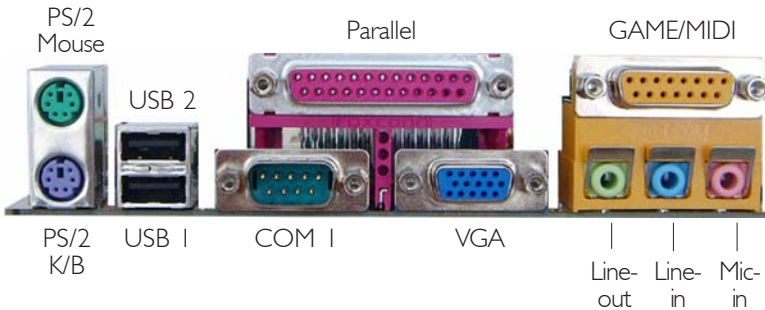

The Rear Panel I/O Ports on PM12-TC

## 2.6.1 PS/2 Mouse and PS/2 Keyboard Ports

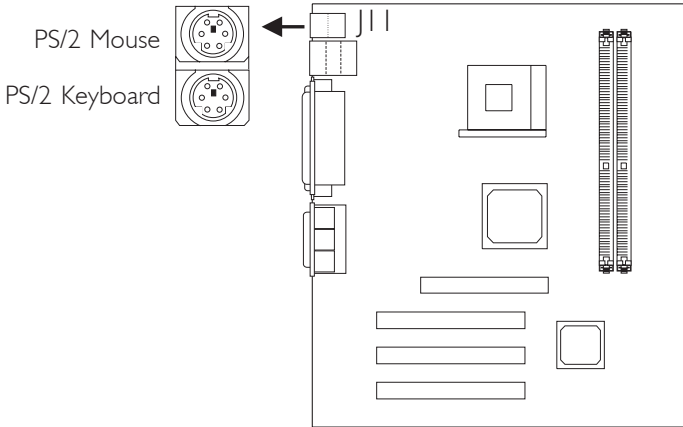

The mainboard is equipped with an onboard PS/2 mouse (Green) and PS/2 keyboard (Purple) ports - both at location J11 of the ATX double deck ports of the mainboard. The PS/2 mouse port uses IRQ12. If a mouse is not connected to this port, the system will reserve IRQ12 for other expansion cards.

The Wake-On-PS/2 Keyboard/Mouse function allows you to use a PS/2 keyboard or PS/2 mouse to wake up the system from the S5 state.

To use this function:

1. JP2 must be set to "2-3 On". Refer to "Jumper Settings for Selecting the PS/2 Power" in this chapter.
2. "PS2KB Wakeup Select" ("IRQ/Event Activity Detect" field) in the Power Management submenu of the BIOS must be set accordingly. Refer to chapter 3 for more information.



**Warning:**

*Make sure to turn off your computer prior to connecting or disconnecting a mouse or keyboard. Failure to do so may damage the mainboard.*



## 2.6.2 RJ45 Fast-Ethernet Port (PM12-TL only)

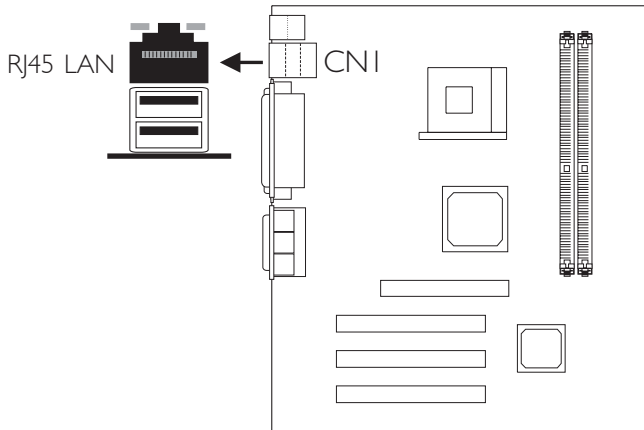

The PM12-TL mainboard is equipped with an onboard RJ45 fast-ethernet LAN port at location CN1 of the ATX double deck ports. It allows the mainboard to connect to a local area network by means of a network hub. You can enable or disable the onboard LAN in the Integrated Peripherals submenu ("VIA OnChip PCI Device" field) of the BIOS.

## 2.6.3 Universal Serial Bus Ports

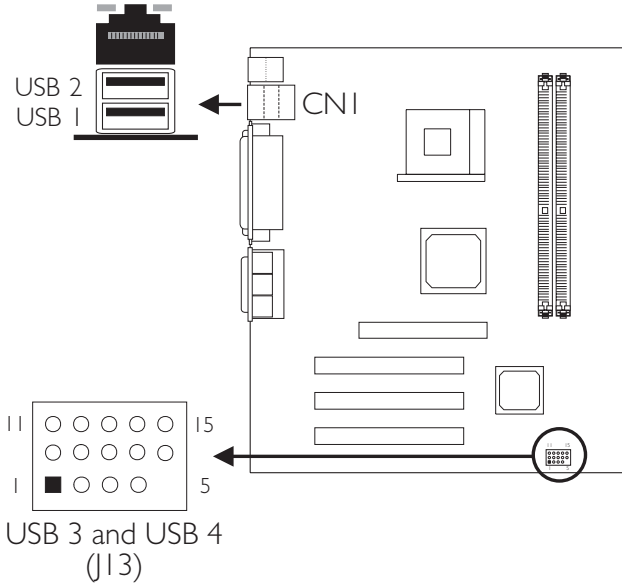

Additional USB Ports (USB 3 and USB 4)

Pin	Function	Pin	Function	Pin	Function
1	VCC	6	VCC	11	Ground
2	UP5-	7	UP6-	12	Ground
3	UP5+	8	UP6+	13	UP5+
4	Ground	9	Ground	14	UP5-
5	Key	10	N. C.	15	VCC

The mainboard is equipped with two onboard USB 2.0 (compliant with USB 1.1) ports (CNI - Black) located at the ATX double deck ports of the board.

The system board is also equipped with J13 for connecting 2 additional external USB 2.0/1.1 ports. The USB 2.0/1.1 ports, which are mounted on a card-edge bracket, will be provided as an option. If you wish to use the optional USB 2.0/1.1 ports, install the card-edge bracket to the system chassis then insert the connector that is attached to the USB 2.0/1.1 port cables to J13. The USB ports' cable connector can be inserted only if pin 1 of the connector is aligned with pin 1 of J13. Now connect the interface cable connector of your USB 2.0/1.1 device to the USB 2.0/1.1 port that is on the bracket.

You can enable or disable the USB ports in the Integrated Peripherals submenu ("OnChip USB Controller" field) of the BIOS.

The Wake-On-USB Keyboard/Mouse function allows you to use a USB keyboard or USB mouse to wake up a system from the S3 (STR - Suspend To RAM) state.

To use this function:

"USB Resume from S3" ("IRQ/Event Activity Detect" field) in the Power Management Setup submenu of the BIOS must be set to Enabled. Refer to chapter 3 for more information.

### 2.6.4 Serial Ports

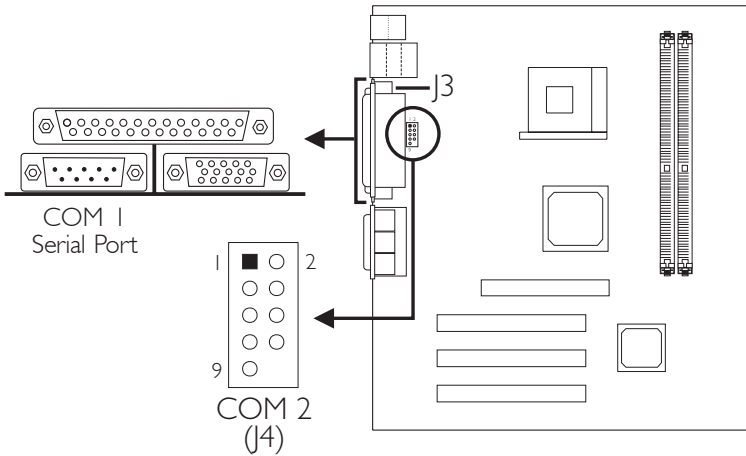

The built-in serial ports are RS-232C asynchronous communication ports with 16C550A-compatible UARTs that can be used with modems, serial printers, remote display terminals, and other serial devices. You can select the serial ports' I/O address in the Integrated Peripherals submenu ("Super IO Device" field) of the BIOS.

#### Connecting the Serial Ports

The system board is equipped with an onboard serial port (J3 - Teal/Turquoise) for COM 1 primary serial port located at the ATX double deck ports of the board. It is also equipped with a 9-pin connector at location J4 for COM 2 secondary serial port.

One card-edge bracket, mounted with a serial port cable, is provided with the system board. If you want to use the secondary serial port, connect the serial port cable to connector J4. Make sure the colored stripe on the ribbon cable is aligned with pin 1 of connector J4. Mount the card-edge bracket to the system chassis.

## 2.6.5 Parallel Port

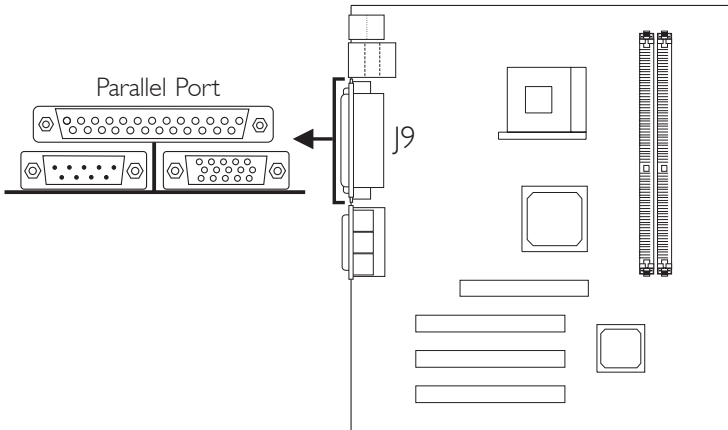

The mainboard has a standard parallel port (J9 - Burgundy) located at the ATX double deck ports of the board for interfacing your PC to a parallel printer. It supports SPP, ECP and EPP modes. You can select the port's mode in the Integrated Peripherals submenu ("Super IO Device" field) of the BIOS.

Setting	Function
SPP (Standard Parallel Port)	Allows normal speed operation but in one direction only.
ECP (Extended Capabilities Port)	Allows parallel port to operate in bidirectional mode and at a speed faster than the SPP's data transfer rate.
EPP (Enhanced Parallel Port)	Allows bidirectional parallel port operation at maximum speed.

## 2.6.6 VGA Port

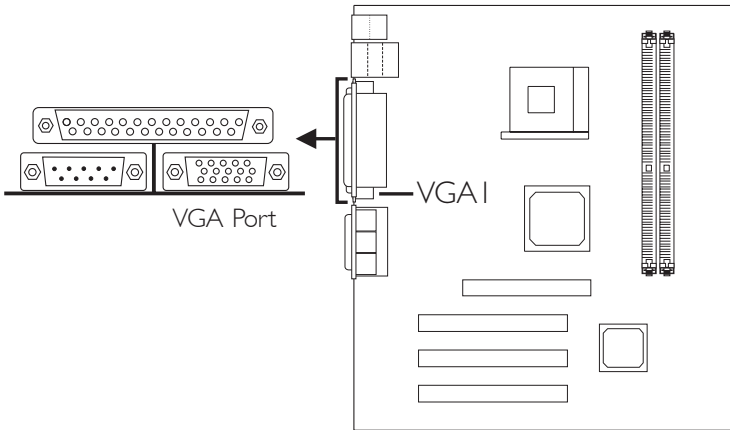

The system board can only be used with an analog video monitor. Connect the monitor's 15-pin D-shell cable connector to the VGA port (VGA I - Blue) located at the ATX double deck ports of the board. If your monitor supports analog video but does not have a 15-pin D-shell connector, see your monitor dealer for the adapter or optional cable. After you plug the monitor cable into the VGA port, gently tighten the cable screws to hold the connector in place. Some monitors have a switch that chooses between analog and TTL (or digital) operation. If your monitor has such a switch, set it for analog.

## 2.6.7 Game/MIDI Port

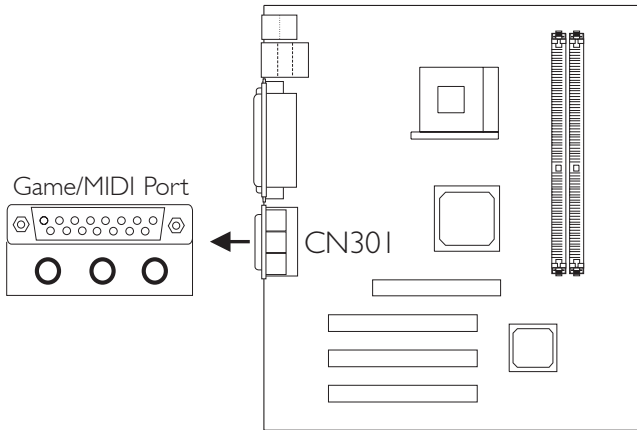

The Game/MIDI port is identical to that of a standard PC game adapter or game I/O port. Connect an analog joystick to the 15-pin D-sub connector (CN301 - Gold) located at the ATX double deck ports of the system board. This port works well with any application that is compatible with the standard PC joystick. You can configure the game port in the Integrated Peripherals submenu ("Super IO Device" field) of the BIOS.

## 2.6.8 Audio Jacks

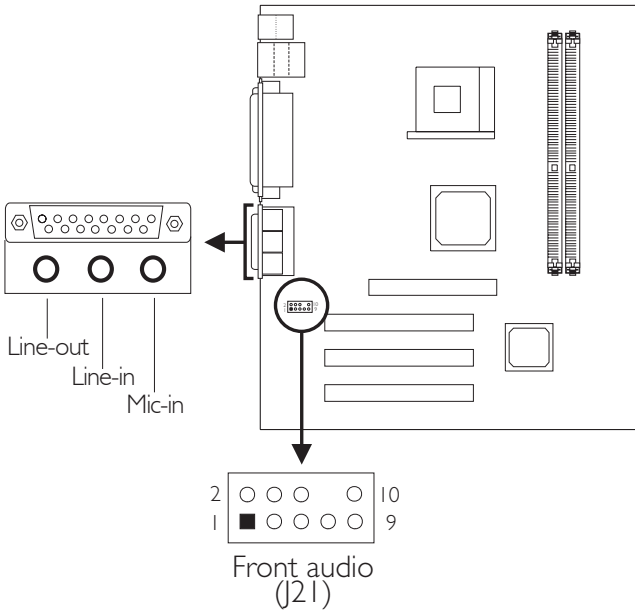

Front Audio (J21)

Pin	Function	Pin	Function
1	Mic+	2	Ground
3	Mic Power	4	AuD_Vcc (Avcc)
5	AuD_R_Out	6	AuD_R_Return (GND)
7	N. C.	8	Key
9	AuD_L_Out	10	AuD_L_Return (GND)



### Onboard Audio Jacks

The mainboard is equipped with 3 audio jacks. A jack is a one-hole connecting interface for inserting a plug.

#### ***Line-out Jack (Lime - CN3A1)***

This jack is used to connect external speakers for audio output from the mainboard.

#### ***Line-in Jack (Light Blue - CN3B1)***

This jack can be connected to the line-out jack of any external audio devices such as Hi-fi set, CD player, AM/FM radio tuner, synthesizer, etc. Connect a stereo cable from the line-out jack of your external device to this line-in jack.

#### ***Mic-in Jack (Pink - CN3C1)***

Connect a microphone to the mic-in jack.

### Front Audio (J21)

J21 provides you the option of connecting another line-out and mic-in jacks.

## 2.7 I/O Connectors

### 2.7.1 Internal Audio Connectors

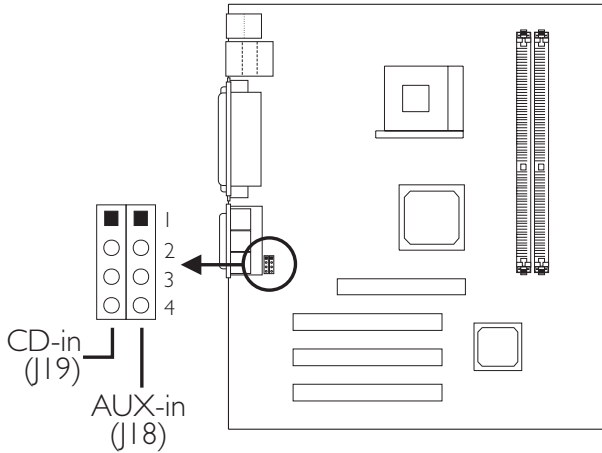

Pin	Function
1	Left audio channel
2	Ground
3	Ground
4	Right audio channel

The CD-in and AUX-in connectors are used to receive audio from a CD-ROM drive, TV tuner or MPEG card.

## 2.7.2 Floppy Disk Drive Connector

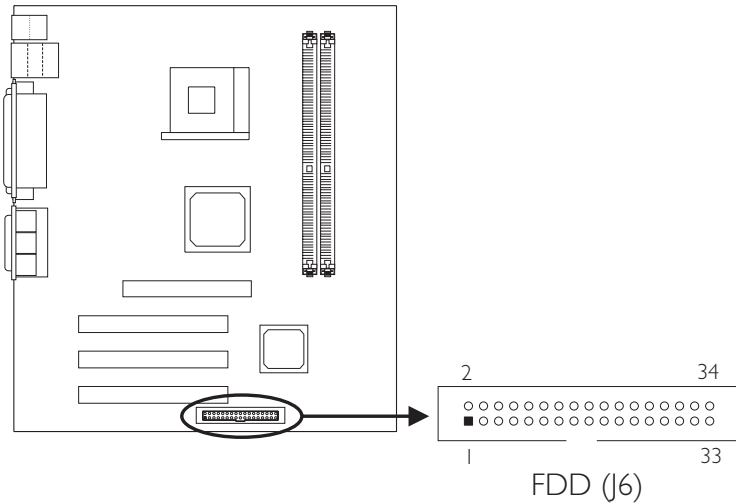

The mainboard is equipped with a shrouded floppy disk drive connector that supports two standard floppy disk drives. To prevent improper floppy cable installation, the shrouded floppy disk header has a keying mechanism. The 34-pin connector on the floppy cable can be placed into the header only if pin 1 of the connector is aligned with pin 1 of the header. You can enable or disable this function in the Integrated Peripherals submenu (“Super IO Device” field) of the BIOS.

### Connecting the Floppy Disk Drive Cable

1. Install the 34-pin header connector of the floppy disk drive cable into the shrouded floppy disk header (J6) on the mainboard. The colored edge of the ribbon should be aligned with pin 1 of J6.
2. Install the other 34-pin header connector(s) into the disk drive(s). Align the colored edge of the daisy chained ribbon cable with pin 1 of the drive edge connector(s). The end-most connector should be attached to the drive you want to designate as Drive A.

### 2.7.3 IDE Disk Drive Connector

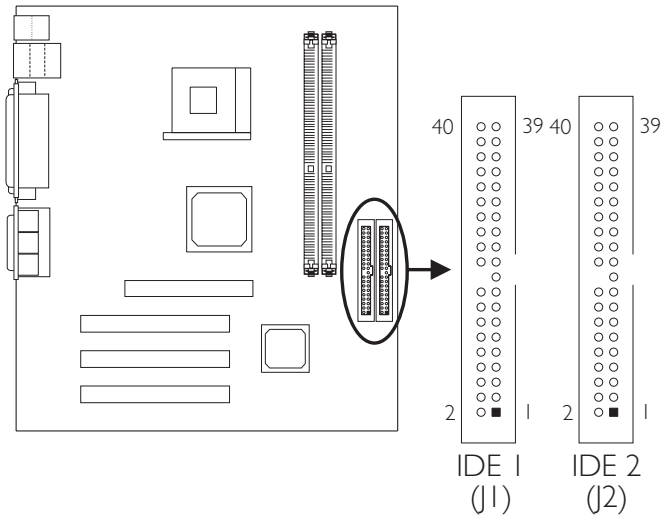

The mainboard is equipped with two shrouded PCI IDE headers that will interface four Enhanced IDE (Integrated Drive Electronics) disk drives. To prevent improper IDE cable installation, each shrouded PCI IDE header has a keying mechanism. The 40-pin connector on the IDE cable can be placed into the header only if pin 1 of the connector is aligned with pin 1 of the header. You can enable or disable the onboard primary or secondary IDE controller in the Integrated Peripherals submenu ("VIA OnChip IDE Device" field) of the BIOS.

#### Connecting the IDE Disk Drive Cable

1. If you are connecting two IDE drives, install the 40-pin connector of the IDE cable into the primary shrouded IDE header (IDE 1 - J1). If you are adding a third or fourth IDE device, install the 40-pin connector of the other IDE cable into the secondary shrouded IDE header (IDE 2 - J2).
2. Install the other 40-pin header connector(s) into the device with the colored edge of the ribbon cable aligned with pin 1 of the drive edge connector(s).

**Note:**

*Refer to your disk drive user's manual for information about selecting proper drive switch settings.*

### Adding a Second IDE Disk Drive

When using two IDE drives, one must be set as the master and the other as the slave. Follow the instructions provided by the drive manufacturer for setting the jumpers and/or switches on the drives.

The mainboard supports Enhanced IDE or ATA-2, ATA/33, ATA/66, ATA/100 and ATA/133 hard drives. We recommend that you use hard drives from the same manufacturer. In a few cases, drives from two different manufacturers will not function properly when used together. The problem lies in the hard drives, not the mainboard.

**Important:**

*If you encounter problems while using an ATAPI CD-ROM drive that is set in Master mode, please set the CD-ROM drive to Slave mode. Some ATAPI CD-ROMs may not be recognized and cannot be used if incorrectly set in Master mode.*

## 2.7.4 IrDA Connector

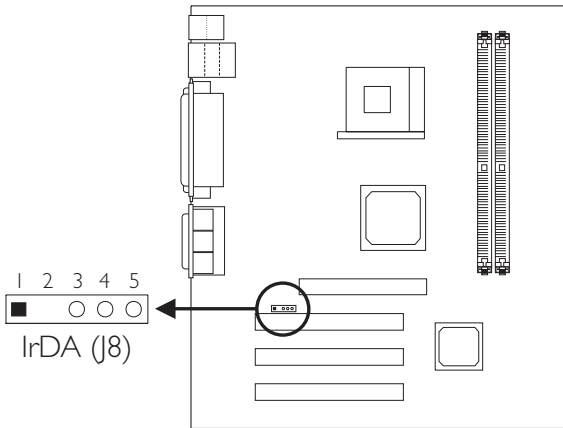

Pin	Function
1	VCC
2	N. C.
3	IRRX
4	Ground
5	IRTX

The mainboard is equipped with an IrDA connector for wireless connectivity between your computer and peripheral devices. The IRDA (Infrared Data Association) specification supports data transfers of 115K baud at a distance of 1 meter.

Connect your IrDA cable to connector J8 on the mainboard. Set "UART Mode Select" in the Integrated Peripherals submenu ("Super IO Device" field) of the BIOS to the type of IrDA standard supported by your device. You must have the proper drivers installed in your operating system to use this connector. Refer to your operating system's manual or documentation.

**Note:**

*The sequence of the pin functions on some IrDA cable may be reversed from the pin function defined on the mainboard. Make sure to connect the cable to the IrDA connector according to their pin functions.*

## 2.7.5 CPU Fan Connector

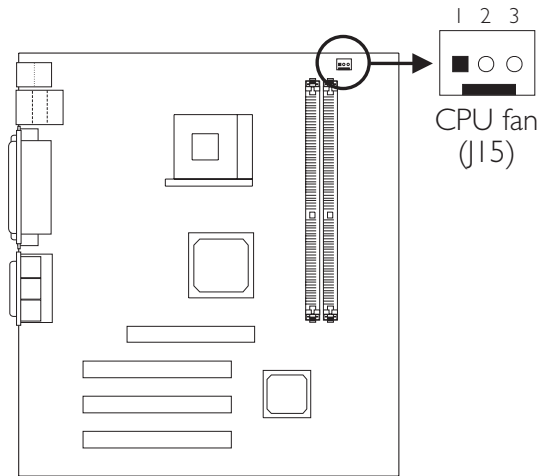

Pin	Function
1	Ground
2	12V
3	N. C.

The processor must be kept cool by using a fan with heatsink. Connect the CPU fan to the 3-pin fan connector at location J15 on the mainboard.

## 2.7.6 Chassis Fan Connector

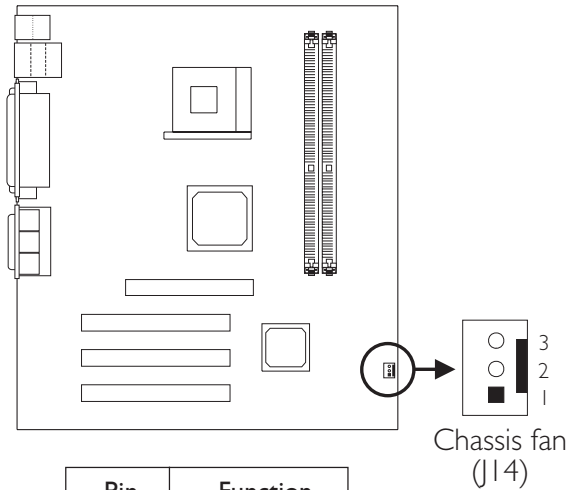

If you are installing a chassis fan in the system unit, connect the fan's connector to location J14 on the mainboard. The fan will provide adequate airflow throughout the chassis to prevent overheating the processor.



## 2.7.7 Wake-On-LAN Connector

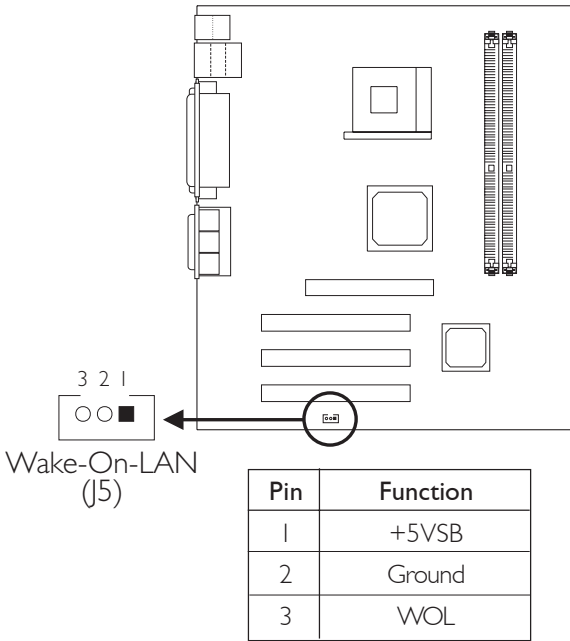

The mainboard supports the Wake-On-LAN function. This function will allow the network to remotely power-on a Soft Power Down (Soft-Off) PC. However, if your system is in the Suspend mode, you can power-on the system only through an IRQ or DMA interrupt.

To use the Wake-On-LAN function, you must enable "Resume on LAN/Ring" in the Power Management Setup ("IRQ/Event Activity Detect" field) of the BIOS. Your LAN card package should include a cable. Connect one end of the cable to the wakeup header on the card and the other end to location J5 on the mainboard. The network will detect Magic Packet and assert a wakeup signal to power-up the system. Refer to the add-in card's manual for details. Note: Your LAN card must support the remote wake up function.



**Important:**

The 5VSB power source of your power supply must support  $\geq 720\text{mA}$ .

## 2.7.8 Wake-On-Ring Connector

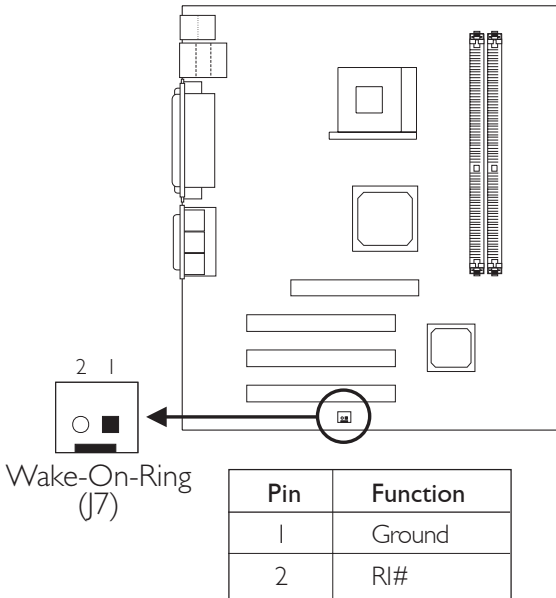

The Wake-On-Ring connector is used to connect to an internal modem card that has the same connector. It will allow the system that is in the Suspend mode or Soft Power Off mode to wake-up/power-on to respond to calls coming through the internal modem card.

To use this function, connect one end of the cable (that came with the card) to the card's wake-on-ring connector and the other end to location J7 on the mainboard. You must also enable "Resume on LAN/Ring" in the Power Management Setup ("IRQ/Event Activity Detect" field) of the BIOS.

If you are using an external modem, the ring-on function will come through the serial port where the external modem is connected.

**Important:**

*If you are using a modem add-in card, the 5VSB power source of your power supply must support  $\geq 720\text{mA}$ .*

## 2.7.9 LEDs

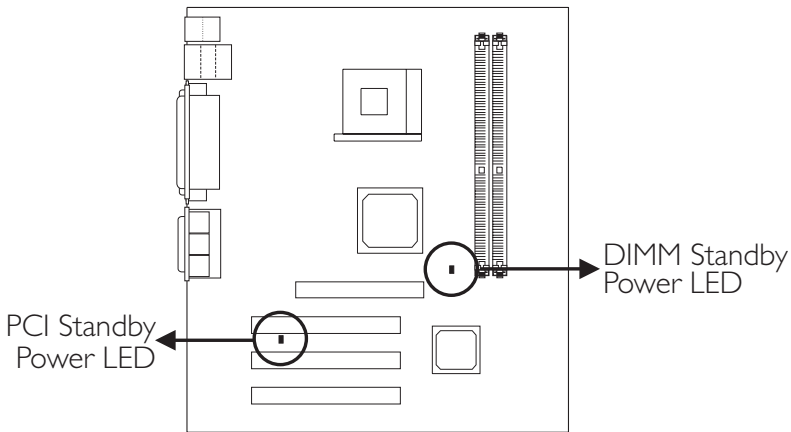

### DIMM Standby Power LED

This LED will turn red when the system's power is on or when it is in the Suspend state (Power On Suspend or Suspend to RAM). It will not light when the system is in the Soft-Off state.

### PCI Standby Power LED

This LED will turn red when the system is in the power-on, Soft-Off or Suspend (Power On Suspend or Suspend to RAM) state.



#### **Important:**

*Lighted LEDs serve as a reminder that you must power-off the system then turn off the power supply's switch or unplug the power cord prior to installing any memory modules or add-in cards.*

## 2.7.10 Power Connectors

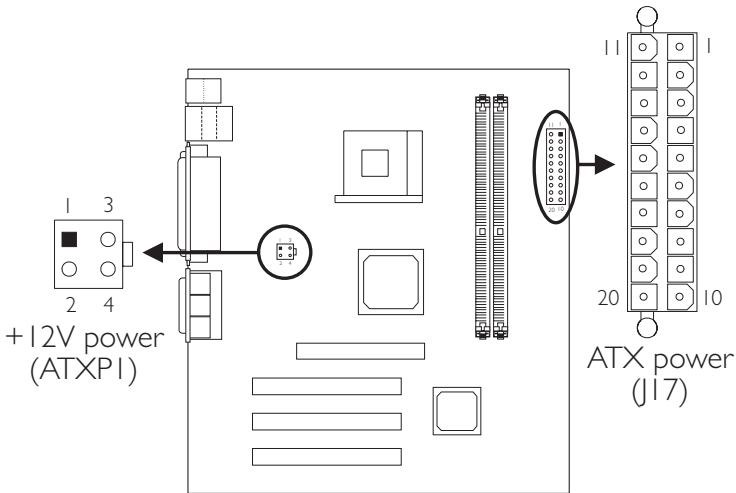

We recommend that you use a power supply that complies with the ATX12V Power Supply Design Guide Version 1.1. Connect the ATX12V power supply's 20-pin ATX main power connector and 4-pin +12V power connector to J17 and ATXPI respectively.

The 4-pin +12V power connector enables the delivery of more +12VDC current to the processor's Voltage Regulator Module (VRM).

The mainboard requires a minimum of 250 Watt power supply to operate. Your system configuration (amount of memory, add-in cards, peripherals, etc.) may exceed the minimum power requirement. To ensure that adequate power is provided, use a 300 Watt (or greater) power supply.

**ATX Main Power Connector**

Pin	Function	Pin	Function
1	3.3V	11	3.3V
2	3.3V	12	-12V
3	Ground	13	Ground
4	+5V	14	PS-ON
5	Ground	15	Ground
6	+5V	16	Ground
7	Ground	17	Ground
8	PW-OK	18	-5V
9	5VSB	19	+5V
10	+12V	20	+5V

**+12V Power Connector**

Pin	Function
1	Ground
2	Ground
3	+12V
4	+12V

## 2.7.1.1 Front Panel Connectors

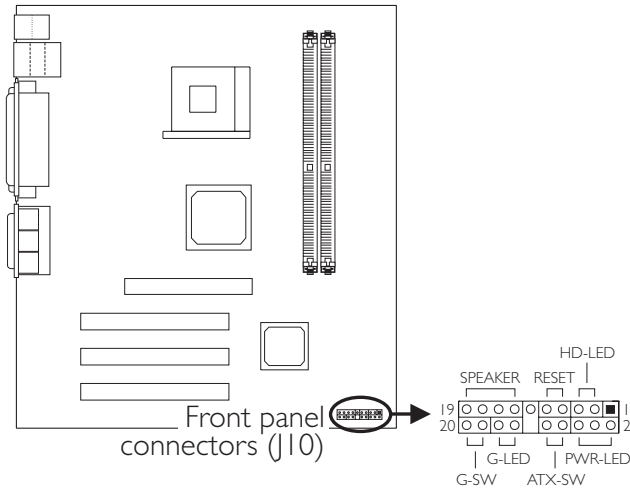
**HD-LED: Primary/Secondary IDE LED**

This LED will light when the hard drive is being accessed.

**G-LED: Green LED**

This LED will not light when the system's power is on or when the system is in the S3 (STR - Suspend To RAM) state. It will light when the system is in the S1 (POS - Power On Suspend) state.

**ATX-SW: ATX Power Switch**

Depending on the setting in the BIOS setup, this switch is a "dual function power button" that will allow your system to enter the Soft-Off or Suspend mode. Refer to "Soft-Off By PWRBTN" in the Power Management Setup (Chapter 3).

**G-SW: Green Switch**

This switch will allow your system to enter the Suspend mode.

**RESET: Reset Switch**

This switch allows you to reboot without having to power off the system thus prolonging the life of the power supply or system.

**SPEAKER: Speaker Connector**

This connects to the speaker installed in the system chassis.

### PWR-LED: Power/Standby LED

When the system's power is on, this LED will light. When the system is in the S1 (POS - Power On Suspend) state, it will blink every second. When the system is in the S3 (STR - Suspend To RAM) state, it will blink 4 times in every second.



#### Note:

*If your system did not boot-up and the Power/Standby LED did not light after it was powered-on, it may indicate that the CPU or memory module was not installed properly. Please make sure they are properly inserted into their corresponding socket.*

	Pin	Pin Assignment
<b>HD-LED</b> (Primary/Secondary IDE LED)	3 5	HDD LED Power HDD
<b>G-LED</b> (Green LED)	14 16	Green LED Power Ground
<b>ATX-SW</b> (ATX power switch)	8 10	PWRBT+ PWRBT-
<b>G-SW</b> (Green switch)	18 20	Ground SMI
<b>RESET</b> (Reset switch)	7 9	Ground H/W Reset
<b>SPEAKER</b> (Speaker connector)	13 15 17 19	Speaker Data N. C. Ground Speaker Power
<b>PWR-LED</b> (Power/Standby LED)	2 4 6	LED Power (+) LED Power (+) LED Power (-) or Standby Signal

# Chapter 3 - Award BIOS Setup Utility

## 3.1 The Basic Input/Output System

The Basic Input/Output System (BIOS) is a program that takes care of the basic level of communication between the processor and peripherals. In addition, the BIOS also contains codes for various advanced features found in this mainboard. This chapter explains the Setup Utility for the Award BIOS.

After you power up the system, the BIOS message appears on the screen and the memory count begins. After the memory test, the following message will appear on the screen:

Press DEL to enter setup

If the message disappears before you respond, restart the system or press the "Reset" button. You may also restart the system by pressing the <Ctrl> <Alt> and <Del> keys simultaneously.

When you press <Del>, the main menu screen will appear:

Phoenix - AwardBIOS CMOS Setup Utility

Standard CMOS Features	Load Fail-Safe Defaults
Advanced BIOS Features	Load Optimized Defaults
Advanced Chipset Features	Set Supervisor Password
Integrated Peripherals	Set User Password
Power Management Setup	Save & Exit Setup
PnP/PCI Configurations	Exit Without Saving
Frequency/Voltage Control	
Esc : Quit	↑↓→← : Select Item
F10 : Save & Exit Setup	
Time, Date, Hard Disk Type...	

### 3.1.1 Standard CMOS Features

Use the arrow keys to highlight "Standard CMOS Features" and press <Enter>. A screen similar to the one on the next page will appear:



Phoenix - AwardBIOS CMOS Setup Utility  
Standard CMOS Features

		Item Help
Date (mm:dd:yy)	Mon, Dec 9 2002	Menu Level Change the day, month, year and century
Time (hh:mm:ss)	4 : 35 : 5	
▶ IDE Primary Master	Press Enter None	
▶ IDE Primary Slave	Press Enter None	
▶ IDE Secondary Master	Press Enter None	
▶ IDE Secondary Slave	Press Enter None	
Drive A	1.44M, 3.5 in.	
Drive B	None	
Video	EGA/VGA	
Halt On	All, But Keyboard	
Base Memory	640K	
Extended Memory	129024K	
Total Memory	130048K	
↑↓→← :Move Enter:Select +/-/PU/PD:Value F10:Save ESC:Exit F1:General Help F5:Previous Values F6:Fail-Safe Defaults F7:Optimized Defaults		

The settings on the screen are for reference only. Your version may not be identical to this one.

### 3.1.1.1 Date

The date format is <day>, <month>, <date>, <year>. Day displays a day, from Sunday to Saturday. Month displays the month, from January to December. Date displays the date, from 1 to 31. Year displays the year, from 1990 to 2098.

### 3.1.1.2 Time

The time format is <hour>, <minute>, <second>. The time is based on the 24-hour military-time clock. For example, 1 p.m. is 13:00:00. Hour displays hours from 00 to 23. Minute displays minutes from 00 to 59. Second displays seconds from 00 to 59.

### 3.1.1.3 IDE Primary Master, IDE Primary Slave, IDE Secondary Master and IDE Secondary Slave

Move the cursor to the "IDE Primary Master", "IDE Primary Slave", "IDE Secondary Master" or "IDE Secondary Slave" field, then press <Enter>.



checking program.

### Cylinder

This field displays the number of cylinders.

### Head

This field displays the number of read/write heads.

### Precomp

This field displays the number of cylinders at which to change the write timing.

### Landing Zone

This field displays the number of cylinders specified as the landing zone for the read/write heads.

### Sector

This field displays the number sectors per track.

#### 3.1.1.4 Drive A and Drive B

These fields identify the types of floppy disk drives installed.

<i>None</i>	No floppy drive is installed
<i>360K, 5.25 in.</i>	5-1/4 in. standard drive; 360KB capacity
<i>1.2M, 5.25 in.</i>	5-1/4 in. AT-type high-density drive; 1.2MB capacity
<i>720K, 3.5 in.</i>	3-1/2 in. double-sided drive; 720KB capacity
<i>1.44M, 3.5 in.</i>	3-1/2 in. double-sided drive; 1.44MB capacity
<i>2.88M, 3.5 in.</i>	3-1/2 in. double-sided drive; 2.88MB capacity

#### 3.1.1.5 Video

This field selects the type of video adapter used for the primary system monitor. Although secondary monitors are supported, you do not have to select the type. The default setting is EGA/VGA.

<i>EGA/VGA</i>	Enhanced Graphics Adapter/Video Graphics Array. For EGA, VGA, SVGA and PGA monitor adapters.
<i>CGA 40</i>	Color Graphics Adapter. Power up in 40-column mode.

<i>CGA 80</i>	Color Graphics Adapter. Power up in 80-column mode.
<i>Mono</i>	Monochrome adapter. Includes high resolution monochrome adapters.

### 3.1.1.6 Halt On

This field determines whether the system will stop if an error is detected during power up. The default setting is All Errors.

<i>No Errors</i>	The system boot will not stop for any errors detected.
<i>All Errors</i>	The system boot will stop whenever the BIOS detects a non-fatal error.
<i>All, But Keyboard</i>	The system boot will not stop for a keyboard error; it will stop for all other errors.
<i>All, But Diskette</i>	The system boot will not stop for a disk error; it will stop for all other errors.
<i>All, But Disk/Key</i>	The system boot will not stop for a disk or keyboard error; it will stop for all other errors.

### 3.1.1.7 Base Memory

Displays the amount of base (or conventional) memory installed in the system. The value of the base memory is typically 512K for systems with 512K memory installed on the motherboard or 640K for systems with 640K or more memory installed on the motherboard.

### 3.1.1.8 Extended Memory

Displays the amount of extended memory detected during boot-up.

### 3.1.1.9 Total Memory

Displays the total memory available in the system.



field. Also, disable this field if you are installing or running certain operating systems like Windows® 98/2000/ME/XP or the operating system may not install nor work.

### 3.1.2.2 CPU L1 & L2 Cache

These fields speed up the memory access. The default value is enabled.

### 3.1.2.3 CPU L2 Cache ECC Checking

The processors supported by the mainboard come with built-in Level 2 cache. By default, ECC is enabled to check the Level 2 cache. If you are not using this function, set this field to Disabled.

### 3.1.2.4 Quick Power On Self Test

This field speeds up Power On Self Test (POST) after you power on the system. When Enabled, the BIOS will shorten or skip some check items during POST.

### 3.1.2.5 First Boot Device, Second Boot Device, Third Boot Device and Boot Other Device

Select the drive to boot first, second and third in the "First Boot Device" "Second Boot Device" and "Third Boot Device" fields respectively. The BIOS will boot the operating system according to the sequence of the drive selected. Set "Boot Other Device" to Enabled if you wish to boot from another device.

### 3.1.2.6 Swap Floppy Drive

When this field is enabled and the system is booting from the floppy drive, the system will boot from drive B instead of drive A. When this option is disabled and the system is booting from the floppy drive, the system will boot from drive A. You must have two floppy drives to use this function.

### 3.1.2.7 Boot Up Floppy Seek

When enabled, the BIOS will check whether the floppy disk drive installed is 40 or 80 tracks. Note that the BIOS cannot distinguish between 720K, 1.2M, 1.44M and 2.88M drive types as they are all 80 tracks. When disabled, the BIOS will not search for the type of floppy disk drive by track number. Note that there will not be any warning message if the drive installed is 360KB.

### 3.1.2.8 Boot Up NumLock Status

This allows you to determine the default state of the numeric keypad. By default, the system boots up with NumLock on wherein the function of the numeric keypad is the number keys. When set to Off, the function of the numeric keypad is the arrow keys.

### 3.1.2.9 Typematic Rate Setting

*Disabled* Continually holding down a key on your keyboard will cause the BIOS to report that the key is down.

*Enabled* The BIOS will not only report that the key is down, but will first wait for a moment, and, if the key is still down, it will begin to report that the key has been depressed repeatedly. For example, you would use such a feature to accelerate cursor movements with the arrow keys. You can then select the typematic rate and typematic delay in the "Typematic Rate (Chars/Sec)" and "Typematic Delay (Msec)" fields below.

### 3.1.2.10 Typematic Rate (Chars/Sec)

This field allows you to select the rate at which the keys are accelerated.

### 3.1.2.11 Typematic Delay (Msec)

This field allows you to select the delay between when the key was first depressed and when the acceleration begins.

### 3.1.2.12 Security Option

This field determines when the system will prompt for the password - everytime the system boots or only when you enter the BIOS setup. Set the password in the Set Supervisor/User Password submenu.

*System* The system will not boot and access to Setup will be denied unless the correct password is entered at the prompt.

*Setup* The system will boot, but access to Setup will be denied unless the correct password is entered at the prompt.

### 3.1.2.13 OS Select for DRAM > 64MB

This field allows you to access the memory that is over 64MB in OS/2. The options are: Non-OS2 and OS2.

### 3.1.2.14 Video BIOS Shadow

Determines whether video BIOS will be copied to RAM. Video Shadow will increase the video speed. Note that some graphics boards require that this option be disabled. The default value is Enabled.

*Enabled* Video shadow is enabled.

*Disabled* Video shadow is disabled.





### 3.1.3.1 DRAM Clock/Drive Control

Move the cursor to this field and press <Enter>. The following screen will appear:

Phoenix - AwardBIOS CMOS Setup Utility		Item Help
DRAM Clock/Drive Control		Menu Level
Current FSB Frequency	133MHz	
Current DRAM Frequency	133MHz	
DRAM Clock	By SPD	
DRAM Timing	By SPD	
X SDRAM CAS Latency	2.5	
X Bank Interleave	Disabled	
X Precharge to Active (Trp)	3T	
X Active to Precharge (Tras)	6T	
X Active to CMD (Trcd)	3T	
X DRAM Command Rate	2T Command	
DRAM Burst Len	4	
↑↓→← Move    Enter:Select    +/-/PU/PD:Value    F10:Save    ESC:Exit    F1:General Help F5:Previous Values    F6:Fail-Safe Defaults    F7:Optimized Defaults		

The settings on the screen are for reference only. Your version may not be identical to this one.

#### Current FSB Frequency

This field shows the detected FSB of the CPU.

#### Current DRAM Frequency

This field shows the detected frequency of the DRAM.

#### DRAM Clock

This field is used to select the clock speed of the DIMM.

**By SPD**      The EEPROM on a DIMM has SPD (Serial Presence Detect) data structure that stores information about the module such as the memory type, memory size, memory speed, etc. When this option is selected, the system will run according to the information in the EEPROM.

*100 MHz*      The memory clock speed will run at 200MHz.

*133 MHz*      The memory clock speed will run at 266MHz.

### DRAM Timing

This field is used to select the timing of the DRAM.

<i>By SPD</i>	The EEPROM on a DIMM has SPD (Serial Presence Detect) data structure that stores information about the module such as the memory type, memory size, memory speed, etc. When this option is selected, the system will run according to the information in the EEPROM. This option is the default setting because it provides the most stable condition for the system. The "SDRAM CAS Latency" to "DRAM Command Rate" fields will show the default settings by SPD.
<i>Manual</i>	If you want a better performance for your system other than the one "by SPD", select "Manual". Then select the best option in the "SDRAM CAS Latency" to "DRAM Command Rate" fields.

### SDRAM CAS Latency

The default setting is 3 which is 3 clock cycles for the CAS latency.

### Bank Interleave

The options are 2 Bank, 4 Bank and Disabled.

### Precharge to Active (Trp)

The options are 2T and 3T.

### Active to Precharge (Tras)

The options are 5T and 6T.

### Active to CMD (Trcd)

The options are 2T and 3T.

### DRAM Command Rate

The options are 1T Command and 2T Command.

### DRAM Burst Len

The options are 4 and 8.



### AGP Driving Value

This field is used to select a value for the AGP Driving control. We recommend that you leave this field in its default setting.

### AGP Fast Write

Select Enabled to support the AGP Fast Write function.

### AGP Master I WS Write

Set this field to Enabled to add one clock tick to AGP write operations.

### AGP Master I WS Read

Set this field to Enabled to add one clock tick to AGP read operations.

## 3.1.3.3 CPU &amp; PCI Bus Control

Move the cursor to this field and press <Enter>. The following screen will appear:

Phoenix - AwardBIOS CMOS Setup Utility		Item Help
CPU to PCI Write Buffer	Enabled	Menu Level
PCI Master 0 WS Write	Enabled	
PCI Delay Transaction	Disabled	
↑↓→← Move    Enter:Select    +/-/PU/PD:Value    F10:Save    ESC:Exit    F1:General Help F5:Previous Values                    F6:Fail-Safe Defaults                    F7:Optimized Defaults		

The settings on the screen are for reference only. Your version may not be identical to this one.

## CPU to PCI Write Buffer

*Enabled*    Writes from the CPU to the PCI bus are buffered to offset the speed difference between the CPU and PCI bus.

*Disabled*    Writes are not buffered therefore the CPU must wait until the write cycle is complete before starting another write cycle.

## PCI Master 0 WS Write

When enabled, writes to the PCI bus are executed with zero wait state.

## PCI Delay Transaction

When enabled, this function frees up the PCI bus for other PCI masters during the PCI-to-ISA transactions. This allows PCI and ISA buses to be used more efficiently and prevents degradation of performance on the PCI bus when ISA accesses are made.

#### 3.1.3.4 Memory Hole

This field is used to select the memory area that must not be addressed to the ISA bus.

#### 3.1.3.5 System BIOS Cacheable

When this field is enabled, accesses to the system BIOS ROM addressed at F0000H-FFFFFH are cached, provided that the cache controller is enabled. The larger the range of the Cache RAM, the higher the efficiency of the system.

#### 3.1.3.6 Video RAM Cacheable

When enabled, it allows the video RAM to be cacheable thus providing better video performance. If your graphics card does not support this function, leave this field in its default setting.

#### 3.1.3.7 VGA Share Memory Size

This field is used to select the memory size that will be shared by the VGA.

#### 3.1.3.8 FB Address Conversion

The options are Enabled and Disabled.

#### 3.1.3.9 FB Page Close Prediction

The options are Enabled and Disabled.

### 3.1.4 Integrated Peripherals

Phoenix - AwardBIOS CMOS Setup Utility		
Integrated Peripherals		
▶ VIA OnChip IDE Device	Press Enter	Item Help
▶ VIA OnChip PCI Device	Press Enter	Menu Level
▶ Super IO Device	Press Enter	
Init Display First	PCI Slot	
OnChip USB Controller	All Enabled	
USB Keyboard Support	Disabled	
IDE HDD Block Mode	Enabled	
↑↓→← Move Enter:Select +/-/PU/PD:Value F10:Save ESC:Exit F1:General Help F5:Previous Values F6:Fail-Safe Defaults F7:Optimized Defaults		

The settings on the screen are for reference only. Your version may not be identical to this one.

#### 3.1.4.1 VIA OnChip IDE Device

Move the cursor to this field and press <Enter>. The following screen will appear:

Phoenix - AwardBIOS CMOS Setup Utility		
VIA OnChip IDE Device		
On-Chip IDE Channel 0	Enabled	Item Help
On-Chip IDE Channel 1	Enabled	Menu Level
IDE Prefetch Mode	Enabled	
IDE Primary Master PIO	Auto	
IDE Primary Slave PIO	Auto	
IDE Secondary Master PIO	Auto	
IDE Secondary Slave PIO	Auto	
IDE Primary Master UDMA	Auto	
IDE Primary Slave UDMA	Auto	
IDE Secondary Master UDMA	Auto	
IDE Secondary Slave UDMA	Auto	
↑↓→← Move Enter:Select +/-/PU/PD:Value F10:Save ESC:Exit F1:General Help F5:Previous Values F6:Fail-Safe Defaults F7:Optimized Defaults		

The settings on the screen are for reference only. Your version may not be identical to this one.



### On-Chip IDE Channel 0 and On-Chip IDE Channel 1

These fields allow you to enable or disable the primary and secondary IDE controller. The default is Enabled. Select Disabled if you want to add a different hard drive controller.

### IDE Prefetch Mode

This allows data and addresses to be stored in the internal buffer of the chip, thus reducing access time. Enable this field to achieve better performance.

### IDE Primary Master/Slave PIO and IDE Secondary Master/Slave PIO

PIO means Programmed Input/Output. Rather than have the BIOS issue a series of commands to effect a transfer to or from the disk drive, PIO allows the BIOS to tell the controller what it wants and then let the controller and the CPU perform the complete task by themselves. Your system supports five modes, 0 (default) to 4, which primarily differ in timing. When Auto is selected, the BIOS will select the best available mode after checking your drive.

- Auto* The BIOS will automatically set the system according to your hard disk drive's timing.
- Mode 0-4* You can select a mode that matches your hard disk drive's timing. Caution: Do not use the wrong setting or you will have drive errors.

### IDE Primary Master/Slave UDMA and IDE Secondary Master/Slave UDMA

These fields allow you to set the Ultra DMA in use. When Auto is selected, the BIOS will select the best available option after checking your hard drive or CD-ROM.

- Auto* The BIOS will automatically detect the settings for you.
- Disabled* The BIOS will not detect these categories.





### UART Mode Select

The mainboard supports IrDA function for wireless connectivity between your computer and peripheral devices. You may not use IrDA (J8) and the COM 2 (J4) serial port at the same time. If you are using the COM 2 serial port, make sure this field is set to Normal.

To use the IrDA function, follow the steps below.

1. Connect your IrDA cable to connector J8 on the mainboard.
2. Set the "UART Mode Select" field to the type of IrDA standard supported by your IrDA peripheral/device. For better transmission of data, your IrDA peripheral device must be within a 30° angle and within a distance of 1 meter.
3. Set the "RxD TxD Active", "IR Transmission Delay", "UR2 Duplex Mode" and "Use IR Pins" fields appropriately.

### RxD, TxD Active

The options are Hi, Lo; Lo, Hi; Lo, Lo; and Hi, Hi.

### IR Transmission Delay

If this option is Enabled, transmission of data will be slower. This is recommended when you encounter transmission problem with your device. The options are: Enabled and Disabled.

### UR2 Duplex Mode

- Half*      Data is completely transmitted before receiving data.
- Full*      Transmits and receives data simultaneously.

### Use IR Pins

The options are IR-Rx2Tx2 and RxD2, TxD2.

### Onboard Parallel Port

- 378/IRQ7, 3BC/IRQ7, 278/IRQ5*      Selects the I/O address and IRQ for the onboard parallel port.
- Disabled*      Disables the onboard parallel port.

### Parallel Port Mode

The options are SPP, EPP, ECP and ECP+EPP. These apply to standard specifications and will depend on the type and speed of your device. Refer to your peripheral's manual for the best option.

#### **SPP**

Allows normal speed operation but in one direction only.

#### **“ECP (Extended Capabilities Port)”**

Allows parallel port to operate in bidirectional mode and at a speed faster than the normal mode's data transfer rate.

#### **“EPP (Enhanced Parallel Port)”**

Allows bidirectional parallel port operation at maximum speed.

### EPP Mode Select

This is used to select the EPP mode.

### ECP Mode Use DMA

This is used to select the DMA channel used for the parallel port.

### Game Port Address

This field is used to select the game port's address. The options are 201, 209 and Disabled.

### Midi Port Address

This field is used to select the MIDI port's address. If you have selected the MIDI port's address, you may select its IRQ in the “Midi Port IRQ” field.

### Midi Port IRQ

This field is used to select the MIDI port's IRQ.

#### 3.1.4.4 Init Display First

This field is used to select whether to initialize the onboard VGA, AGP or PCI first when the system boots.

*Onboard/AGP* When the system boots, it will first initialize the onboard VGA or AGP.

*PCI Slot* When the system boots, it will first initialize PCI.

#### 3.1.4.5 OnChip USB Controller

This field is used to select the USB ports you want Enabled.

#### 3.1.4.6 USB Keyboard Support

By default, USB Keyboard Support is Disabled. However, if you are using a USB keyboard under DOS, make sure to enable this function.

#### 3.1.4.7 IDE HDD Block Mode

*Enabled* The IDE HDD uses the block mode. The system BIOS will check the hard disk drive for the maximum block size the system can transfer. The block size will depend on the type of hard disk drive.

*Disabled* The IDE HDD uses the standard mode.



### 3.1.5.3 Power Management Option

This field allows you to select the type (or degree) of power saving by changing the length of idle time that elapses before the "Suspend Mode" field is activated.

<i>Min Saving</i>	Minimum power saving time for Suspend mode = 1 hr.
<i>Max Saving</i>	Maximum power saving time for Suspend mode = 1 min.
<i>User Define</i>	Allows you to set the power saving time in the "Suspend Mode" field.

### 3.1.5.4 HDD Power Down

After the set time of system inactivity, the hard disk drive will be powered down while all other devices remain active.

### 3.1.5.5 Suspend Mode

This is selectable only when the Power Management field is set to User Define. When the system enters the Suspend mode according to the power saving time selected, the CPU and onboard peripherals will be shut off.

### 3.1.5.6 Video Off Option

<i>Always On</i>	The system BIOS will never turn off the screen.
<i>Suspend -&gt; Off</i>	The screen is off when the system is in the Suspend mode.

### 3.1.5.7 Video Off Method

This determines the manner in which the monitor is blanked.

<i>VIH SYNC + Blank</i>	This will cause the system to turn off the vertical and horizontal synchronization ports and write blanks to the video buffer.
<i>Blank Screen</i>	This only writes blanks to the video buffer.
<i>DPMS Support</i>	Initializes display power management signaling. Select this if your video board supports it.



### 3.1.5.8 MODEM Use IRQ

This field is used to set an IRQ channel for the modem installed in your system.

### 3.1.5.9 Soft-Off by PWRBTN

This field allows you to select the method of powering off your system.

*Delay 4 Sec* Regardless of whether the Power Management field is enabled or disabled, if the power button is pushed and released in less than 4 sec, the system enters the Suspend mode. The purpose of this function is to prevent the system from powering off in case you accidentally “hit” or pushed the power button. Push and release again in less than 4 sec to restore. Pushing the power button for more than 4 seconds will power off the system.

*Instant-Off* Pressing and then releasing the power button at once will immediately power off your system.

### 3.1.5.10 Run VGABIOS if S3 Resume

When this field is set to Auto, the system will initialize the VGA BIOS when it wakes up from the S3 state.

### 3.1.5.11 PWR Lost Resume State

*Keep Off* When power returns after an AC power failure, the system's power is off. You must press the Power button to power-on the system.

*Turn On* When power returns after an AC power failure, the system will automatically power-on.

*Last State* When power returns after an AC power failure, the system will return to the state where you left off before power failure occurs. If the system's power is off when AC power failure occurs, it will remain off when power returns. If the system's power is on when AC power failure occurs, the system will power-on when power returns.

## 3.1.5.12 IRQ/Event Activity Detect

Move the cursor to this field and press <Enter>. The following screen will appear:

Phoenix - AwardBIOS CMOS Setup Utility		Item Help
IRQ/Event Activity Detect		Menu Level
PS2KB Wakeup Select	Disabled	
USB Resume from S3	Disabled	
VGA	Off	
LPT & COM	LPT/COM	
HDD & FDD	On	
PCI Master	Off	
Resume On PCI Event	Disabled	
Resume On LAN/Ring	Disabled	
Resume On Alarm	Disabled	
Date (of Month)	0	
Resume Time (hh:mm:ss)	0 : 0 : 0	
► IRQs Activity Monitoring	Press Enter	
↑↓→← Move Enter:Select +/-/PU/PD:Value F10:Save ESC:Exit F1:General Help		
F5:Previous Values F6:Fail-Safe Defaults F7:Optimized Defaults		

The settings on the screen are for reference only. Your version may not be identical to this one.

## PS2KB Wakeup Select

*Password* To use a password to wake up the system, select this option then press <Enter>. Enter your password. You can enter up to 5 characters. Type in exactly the same password to confirm, then press <Enter>.

**Important:**

*If you forgot the password, you must power-off the system, unplug the power cord and clear the CMOS data. Follow the steps in the "Jumper Settings for Clearing CMOS Data" section in chapter 2.*

*Ctrl+F1* Use the <Ctrl> and <F1> keys to wake up the system.

*Disabled* Disables the keyboard password function.

### USB Resume from S3

This function, when enabled, allows you to use a USB keyboard or USB mouse to wake up a system that is in the S3 (STR - Suspend To RAM) state.

### VGA

When set to On, the system will respond and wake up to any VGA activity.

### LPT & COM

Select the port you would like the system to respond and wake up when an event occurs on that port.

### HDD & FDD

When set to On, the system will respond and wake up to any hard drive or floppy drive activity.

### PCI Master

When set to On, the system will respond and wake up to any PCI or bus master activity.

### Resume on PCI Event

Set this field to Enabled if your PCI card such as LAN card or modem card uses the PCI PME (Power Management Event) signal to remotely wake up the PC. Refer to the card's documentation for more information.

### Resume On LAN/Ring

This field allows you to enable the Wake-On-LAN and Wake-On-Ring functions.

- If you are using a LAN card that supports the remote wake up function, set this field to Enabled. This will allow the network to remotely wake up a Soft Power Down (Soft-Off) PC. However, if your system is in the Suspend mode, you can wake up the system only through an IRQ or DMA interrupt. Your LAN card must support the remote wake up function. Refer to "Wake-On-LAN Connector" in chapter 2 for more information.

- When enabled, the system will power-on to respond to calls coming through an external or internal modem. Refer to “Wake-On-Ring Connector” in chapter 2 for more information.

### Resume on Alarm

*Enabled* When Enabled, you can set the date and time you would like the Soft Power Down (Soft-Off) PC to power-on in the “Date (of Month)” and “Resume Time (hh:mm:ss)” fields. However, if the system is being accessed by incoming calls or the network prior to the date and time set in these fields, the system will give priority to the incoming calls or network.

*Disabled* Disables the automatic power-on function. (default)

### Date (of Month)

*0* The system will power-on everyday according to the time set in the “Resume Time (hh:mm:ss)” field.

*1-31* Select a date you would like the system to power-on. The system will power-on on the set date, and time set in the “Resume Time (hh:mm:ss)” field.

### Resume Time (hh:mm:ss)

This is used to set the time you would like the system to power-on. If you want the system to power-on everyday as set in the “Date (of Month)” field, the time set in this field must be later than the time of the RTC set in the Standard CMOS Features submenu.

## IRQs Activity Monitoring

Move the cursor to this field and press <Enter>. The following screen will appear:

Phoenix - AwardBIOS CMOS Setup Utility  
IRQs Activity Monitoring

Primary INTR	ON	Item Help
IRQ3 (COM 2)	Enabled	Menu Level
IRQ4 (COM 1)	Enabled	
IRQ5 (LPT 2)	Enabled	
IRQ6 (Floppy Disk)	Enabled	
IRQ7 (LPT 1)	Enabled	
IRQ8 (RTC Alarm)	Disabled	
IRQ9 (IRQ2 Redir)	Disabled	
IRQ10 (Reserved)	Disabled	
IRQ11 (Reserved)	Disabled	
IRQ12 (PS/2 Mouse)	Enabled	
IRQ13 (Coprocessor)	Enabled	
IRQ14 (Hard Disk)	Enabled	
IRQ15 (Reserved)	Disabled	

↑↓→← Move    Enter:Select    +/-/PU/PD:Value    F10:Save    ESC:Exit    F1:General Help  
 F5:Previous Values    F6:Fail-Safe Defaults    F7:Optimized Defaults

The settings on the screen are for reference only. Your version may not be identical to this one.

When the “Primary INTR”, and “IRQ3” - “IRQ15” fields are enabled, access to the specified IRQ will cause the system to wake up completely from the power management mode. When disabled, the system will not wake up from the power management mode despite access to the specified IRQ.

### 3.1.6 PnP/PCI Configurations

This section shows how to configure the PCI bus system. It covers some very technical items and it is strongly recommended that only experienced users should make any changes to the default settings.

Phoenix - AwardBIOS CMOS Setup Utility  
PnP/PCI Configurations

		Item Help
PNP OS Installed	No	Menu Level Default is Disabled. Select Enabled to reset Extended System Configuration Data (ESCD) when you exit Setup if you have installed a new add-on and the system reconfiguration has caused such a serious conflict that the OS cannot boot.
Reset Configuration Data	Disabled	
Resources Controlled By	Auto(ESCD)	
X IRQ Resources	Press Enter	
PCI/VGA Palette Snoop	Disabled	
Assign IRQ For VGA	Enabled	
Assign IRQ For USB	Enabled	
PCI Slot 1 Use IRQ	Auto	
PCI Slot 2 Use IRQ	Auto	
PCI Slot 3 Use IRQ	Auto	
↑↓→← Move Enter:Select +/-/PU/PD:Value F10:Save ESC:Exit F1:General Help F5:Previous Values F6:Fail-Safe Defaults F7:Optimized Defaults		

The settings on the screen are for reference only. Your version may not be identical to this one.

#### 3.1.6.1 PNP OS Installed

The default setting is "No". The BIOS will detect the Plug and Play devices for some compatible resources.

#### 3.1.6.2 Reset Configuration Data

*Enabled* The BIOS will reset the Extended System Configuration Data (ESCD) once automatically. It will then recreate a new set of configuration data.

*Disabled* The BIOS will not reset the configuration data.

#### 3.1.6.3 Resources Controlled By

The Award Plug and Play BIOS has the capability to automatically configure all of the boot and Plug and Play compatible devices.

*Auto(ESCD)* The system will automatically detect the settings for you.

*Manual* Choose the specific IRQ resources in the "IRQ Resources" field.

#### 3.1.6.4 IRQ Resources

Move the cursor to this field and press <Enter>. The “IRQ-3” to “IRQ-15” fields will appear. Set each system interrupt to either PCI Device or Reserved.

#### 3.1.6.5 PCI/VGA Palette Snoop

This field determines whether the MPEG ISA/VESA VGA cards can work with PCI/VGA or not. The default value is Disabled.

*Enabled* MPEG ISA/VESA VGA cards work with PCI/VGA.

*Disabled* MPEG ISA/VESA VGA cards does not work with PCI/VGA.

#### 3.1.6.6 Assign IRQ for VGA

When Enabled, the system automatically assigns an IRQ for the VGA card installed. Your VGA card will need an IRQ only when using the video capture function of the card. If you are not using this function and a new device requires an IRQ, you can set this field to Disabled. The IRQ (previously occupied by the VGA card) will be available for your new device.

#### 3.1.6.7 Assign IRQ for USB

When Enabled, the system automatically assigns an IRQ for the USB device connected to your system. However, if you are not using USB devices and a new device requires an IRQ, set this field to Disabled. The IRQ previously occupied by the USB device will be available for the new device.

### 3.1.6.8 PCI Slot 1 Use IRQ to PCI Slot 3 Use IRQ

By default, an IRQ is automatically assigned to the PCI devices that are installed in the PCI slots.

If a PCI device has not been assigned an IRQ, you must manually assign an IRQ for the device. During system boot-up, you will see "NA" for the device that does not have an IRQ assigned.





### 3.1.7.4 CPU Clock

This field provides several options for selecting the external system bus clock of the CPU. The available options allow you to adjust the CPU's bus clock in 1MHz increment. The default setting is "100MHz".

**Important:**

*Overclocking may result in the processor's or system's instability and is not guaranteed to provide better system performance.*

If, in the "CPU Clock" or "CPU Clock Ratio" field, you selected an option other than the default setting and is unable to boot up the system, there are 2 methods of booting up the system and going back to its default setting.

Method 1:

Clear the CMOS data by setting JPI to 2-3 On. All fields in the BIOS Setup will automatically be set to their default settings.

Method 2:

Press the <Insert> key and power button simultaneously, then release the power button first. Keep-on pressing the <Insert> key until the power-on screen appears. This will allow the system to boot according to the FSB of the processor. Now press the <Del> key to enter the main menu of the BIOS. Select "Frequency/Voltage Control" and set the "CPU Clock" or "CPU Clock Ratio" field to its default setting or an appropriate bus clock or ratio.

**Note:**

*Use a PS/2 or AT (requires a DIN to mini DIN adapter) keyboard for method 2.*

### 3.1.8 Load Fail-Safe Defaults

The “Load Fail-Safe Defaults” option loads the troubleshooting default values permanently stored in the ROM chips. These settings are not optimal and turn off all high performance features. You should use these values only if you have hardware problems. Highlight this option in the main menu and press <Enter>. The message below will appear:

Load Fail-Safe Defaults (Y/N)? N

If you want to proceed, type <Y> and press <Enter>. The default settings will be loaded.

### 3.1.9 Load Optimized Defaults

The “Load Optimized Defaults” option loads optimized settings from the BIOS ROM. Use the default values as standard values for your system. Highlight this option in the main menu and press <Enter>. The message below will appear:

Load Optimized Defaults (Y/N)? N

Type <Y> and press <Enter> to load the Setup default values.

### 3.1.10 Set Supervisor Password

If you want to protect your system and setup from unauthorized entry, set a supervisor's password with the "System" option selected in the Advanced BIOS Features. If you want to protect access to setup only, but not your system, set a supervisor's password with the "Setup" option selected in the Advanced BIOS Features. You will not be prompted for a password when you cold boot the system.

Use the arrow keys to highlight "Set Supervisor Password" and press <Enter>. The message below will appear:

Enter Password:

Type in the password. You are limited to eight characters. When done, the message below will appear:

Confirm Password:

You are asked to verify the password. Type in exactly the same password. If you type in a wrong password, you will be prompted to enter the correct password again. To delete or disable the password function, highlight "Set Supervisor Password" and press <Enter>, instead of typing in a new password. Press the <Esc> key to return to the main menu.

### 3.1.11 Set User Password

If you want another user to have access only to your system but not to setup, set a user's password with the "System" option selected in the Advanced BIOS Features. If you want a user to enter a password when trying to access setup, set a user's password with the "Setup" option selected in the Advanced BIOS Features.

Using user's password to enter Setup allows a user to access only "Set User Password" that appears in the main menu screen. Access to all other options is denied. To set, confirm, verify, disable or delete a user's password, follow the procedures described in the section "Set Supervisor Password".

### 3.1.12 Save & Exit Setup

When all the changes have been made, highlight “Save & Exit Setup” and press <Enter>. The message below will appear:

Save to CMOS and Exit (Y/N)? N

Type “Y” and press <Enter>. The modifications you have made will be written into the CMOS memory, and the system will reboot. You will once again see the initial diagnostics on the screen. If you wish to make additional changes to the setup, press <Ctrl> <Alt> <Esc> simultaneously or <Del> after memory testing is done.

### 3.1.13 Exit Without Saving

When you do not want to save the changes you have made, highlight “Exit Without Saving” and press <Enter>. The message below will appear:

Quit Without Saving (Y/N)? N

Type “Y” and press <Enter>. The system will reboot and you will once again see the initial diagnostics on the screen. If you wish to make any changes to the setup, press <Ctrl> <Alt> <Esc> simultaneously or <Del> after memory testing is done.

## 3.2 Updating the BIOS

To update the BIOS, you will need the new BIOS file and a flash utility, AWDFLASH.EXE. You can download them from DFI's web site or contact technical support or your sales representative.

1. Save the new BIOS file along with the flash utility AWDFLASH.EXE to a floppy disk.
2. Reboot the system and enter the Award BIOS Setup Utility to set the first boot drive to "Floppy".
3. Save the setting and reboot the system.
4. After the system booted from the floppy disk, execute the flash utility by typing AWDFLASH.EXE. The following screen will appear:

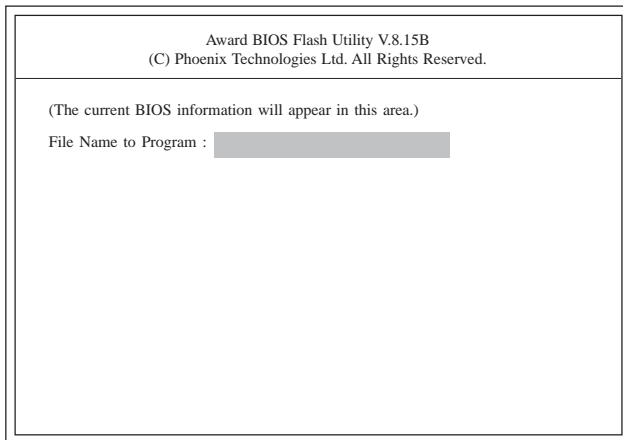

5. Type the new BIOS file name onto the gray area that is next to "File Name to Program" then press <Enter>.

6. The following will appear:

Do You Want to Save BIOS (Y/N)

This question refers to the current existing BIOS in your system. We recommend that you save the current BIOS and its flash utility; just in case you need to reinstall the BIOS. To save the current BIOS, press <Y> then enter the file name of the current BIOS. Otherwise, press <N>.

7. The following will then appear:

Press "Y" to Program or "N" to Exit

8. Press <Y> to flash the new BIOS.

## Chapter 4 - Supported Software

---

### 4.1 Desktop Management Interface (DMI)

The mainboard comes with a DMI built into the BIOS. DMI, along with the appropriately networked software, is designed to make inventory, maintenance and troubleshooting of computer systems easier. With DMI, a network administrator or MIS engineer can remotely access some information about a particular computer system without physically going to it. Quite often a service call may be unnecessary as the problem can be solved remotely.

The DMI utility in the BIOS automatically records various information about your system configuration. Information about the type and speed of CPU, type and amount of memory for each memory slot, BIOS revision level, types of add-in PCI boards and components, certain revision numbers of hardware installed, etc. are automatically detected and stored in the DMI pool, which is a part of the mainboard's Plug and Play BIOS. Additional information, such as ISA based peripherals, which may not be automatically detected, can be manually recorded in the DMI pool by using the Add DMI menu. The DMI pool data is then verified or updated whenever the system hardware or setup is altered.

#### 4.1.1 Running the DMI Utility

To run the DMI utility, type: DMICFG.EXE. You can download this utility from [ftp.dfiusa.com](http://ftp.dfiusa.com) - /utilities/DMI directory.

The DMI utility must run in real mode with at least 180K of base memory. Memory managers like HIMEM.SYS (required by Windows) must not be installed. You may do this by using one of the 3 methods listed below.

1. Boot up from a system diskette without the AUTOEXEC.BAT and CONFIG.SYS files,
2. "REM" HIMEM.SYS in the CONFIG.SYS, or
3. Press <F5> during bootup to bypass your AUTOEXEC.BAT and CONFIG.SYS files.



## 4.1.2 Using the DMI Utility

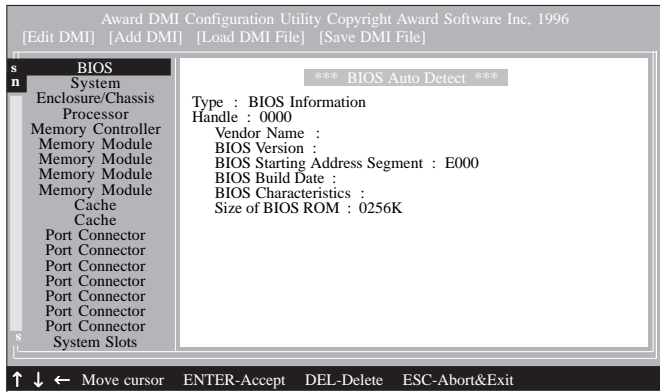

The four menus located on top of the DMI Configuration Utility screen are Edit DMI, Add DMI, Load DMI File and Save DMI File. Use the ← or → (left or right) arrow keys to select a menu from the Menu bar.

On the left side of the screen is a list of the system configuration items. Use the ↑ or ↓ (up or down) arrow keys to select an item.

The commands at the bottom of the screen will allow you to navigate through the various setup menus.

### Edit DMI

1. Use the ← or → arrow keys to select the Edit DMI menu.
2. Highlight the item on the left screen that you would like to edit by using the ↑ or ↓ arrow keys, then press <Enter>.
3. The cursor will move to the screen you select allowing you to edit information. The screen will also display the auto-detected information.
4. Press <F10> to update the edited information into the flash ROM.

## Add DMI

1. Use the ← or → arrow keys to select the Add DMI menu.
2. Highlight the item on the left screen that you would like to add by using the ↑ or ↓ arrow keys, then press <Enter>.
3. The cursor will move to the screen you select allowing you to enter information about the added item.
4. Press <F10> to save information into the flash ROM.

To view information about the added items, go to the Edit DMI menu.

## Load DMI File

1. Use the ← or → arrow keys to select the Load DMI File menu.
2. The following message will appear:  
*Press [Enter] to select DMI file for load*  
Press <Enter>.
3. The DMI files will appear on the screen. Select the file you would like to load and press <Enter>.
4. The following message will appear:

*Do you want to execute? (Y/N)*

Type <Y>. All previous DMI structures will be destroyed and the new file will be saved into the flash ROM.

## Save DMI File

1. Use the ← or → arrow keys to select the Save DMI File menu.
2. The following message will appear:  
*Press [Enter] to select DMI file for save*  
Press <Enter>.
3. Enter the directory and filename under which you would like the DMI file saved.

## 4.2 Drivers, Utilities and Software Applications

The CD that came with the system board contains drivers, utilities and software applications required to enhance the performance of the system board.

Insert the CD into a CD-ROM drive. The autorun screen (Mainboard Utility CD) will appear. If after inserting the CD, "Autorun" did not automatically start (which is, the Mainboard Utility CD screen did not appear), please go directly to the root directory of the CD and double-click "Setup".



### 4.2.1 VIA® Service Pack

The VIA® Service Pack contains the following drivers.

- VIA ATAPI Vendor Support Driver
- AGP VxD Driver
- IRQ Routing Miniport Driver
- VIA INF Driver

To install VIA Service Pack, please follow the steps below.

1. On the left side of the autorun screen, click the “CHIPSET” icon.
2. Click “VIA Service Pack” on the main screen. The following screen will appear:

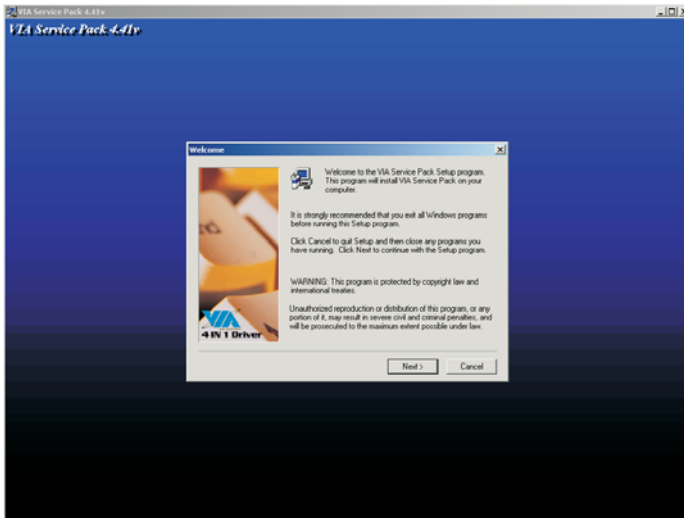

3. Click “Next”. Please read the “VIA Service Pack Readme” carefully before proceeding to step 3.
4. Follow the prompts on the screen to complete the installation.
5. Reboot the system for the drivers to take effect.

### VIA® Service Pack Installation Notes

The “AGP VxD Driver” and “VIA INF Driver” drivers in the “VIA Service Pack” are supported in Windows® 95, Windows® 98, Windows® 98 SE, Windows® ME and Windows® 2000.

You must first install VIA® Service Pack prior to installing any other drivers. However, this may not be the case for some AGP cards. Please read carefully the following information.



**Important:**

*The VGA driver that came with some AGP cards is already bundled with the AGP VxD driver. Since the version of the bundled VxD driver may be older than the one provided in the CD, installing the bundled VxD driver may cause problems. If you are using this type of card, we recommend that you install first the AGP card's VGA driver before installing the VIA Service Pack.*

## 4.2.2 S3 ProSavage VGA Drivers

To install the driver, please follow the steps below.

1. On the left side of the autorun screen, click the “GRAPHICS” icon.
2. Click “S3 ProSavage VGA Drivers” on the main screen. The following screen will appear:

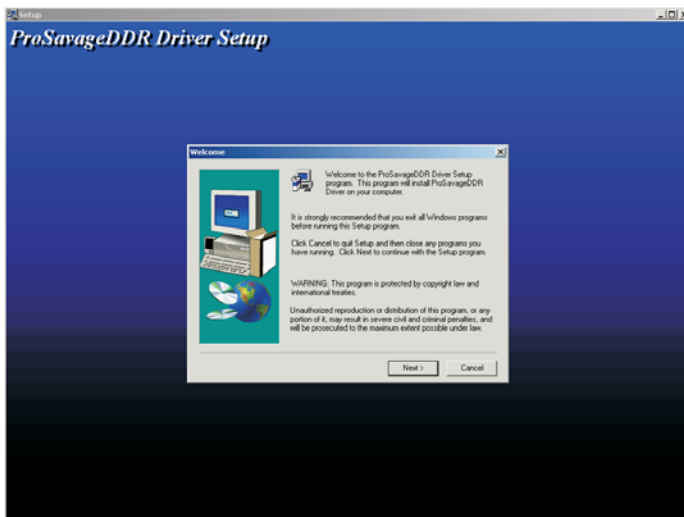

3. Follow the prompts on the screen to complete installation.
4. Restart the system.

### 4.2.3 Realtek Audio Drivers

The Realtek audio drivers support the Windows® 98, Windows® 98 SE, Windows® ME, Windows NT® 4.0, Windows® 2000 and Windows® XP operating systems.

To install the audio driver, please follow the steps below.

1. On the left side of the autorun screen, click the “AUDIO” icon.
2. Click ““Realtek Audio Drivers”” on the main screen. The screen below will appear:

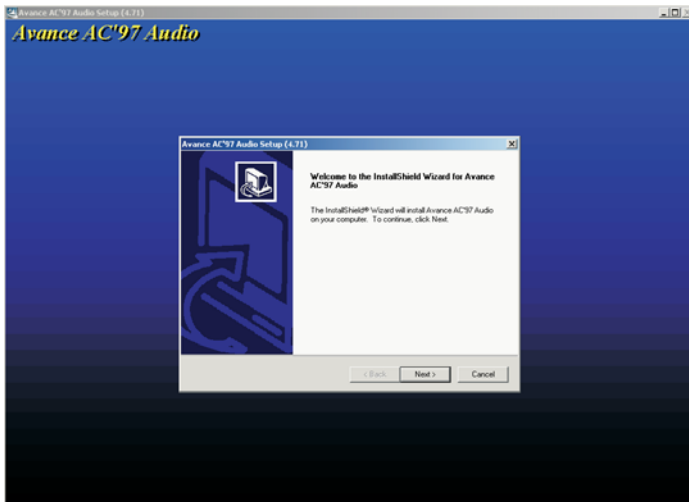

3. Follow the prompts on the screen to complete installation.
4. Restart the system.

### 4.2.4 VIA USB 2.0 Drivers

To install the USB 2.0 driver, please follow the steps below.

1. On the left side of the autorun screen, click the "USB" icon.
2. Click "VIA USB 2.0 Drivers". The following screen will appear:

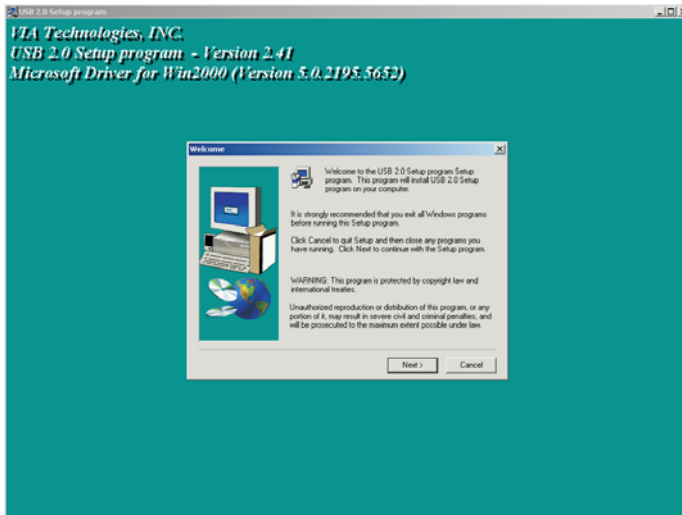

3. Follow the prompts on the screen to complete installation.
4. Restart the system.



## 4.2.5 VIA LAN Drivers (PM12-TL only)

The LAN drivers for Windows® 98, Windows® 98 SE, Windows® ME, Windows® 2000 and Windows® XP support “Autorun”.

To install the LAN driver, please follow the steps below.

1. On the left side of the autorun screen, click the “NETWORK” icon.
2. Click “VIA LAN Drivers”. The following screen will appear:

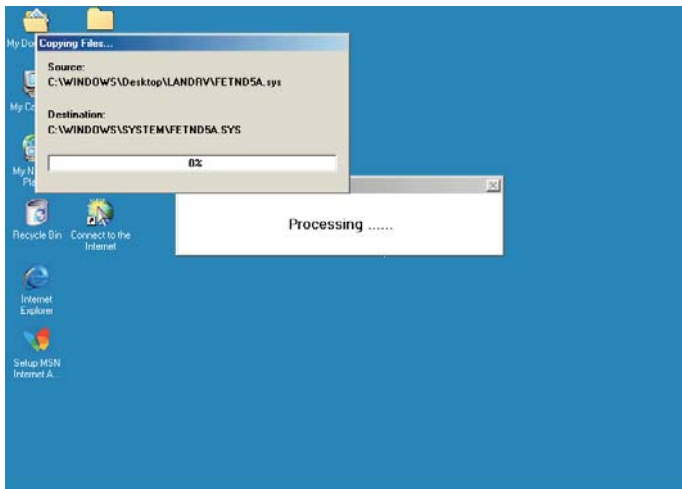

3. Follow the prompts on the screen to complete installation.
4. Reboot the system for the driver to take effect.

The LAN driver for Windows NT® 4.0 does not support “Autorun”. Once the system has detected the fast ethernet controller, it will prompt you to install the driver for Windows NT® 4.0. The driver is in the “LANDRV” root directory of the CD. Please refer to README for the exact location of the drivers.

### 4.2.6 Microsoft DirectX 8.1

To install, please follow the steps below.

1. On the left side of the autorun screen, click the "TOOLS" icon.
2. Click "Microsoft DirectX 8.1" on the main screen. The screen below will appear:

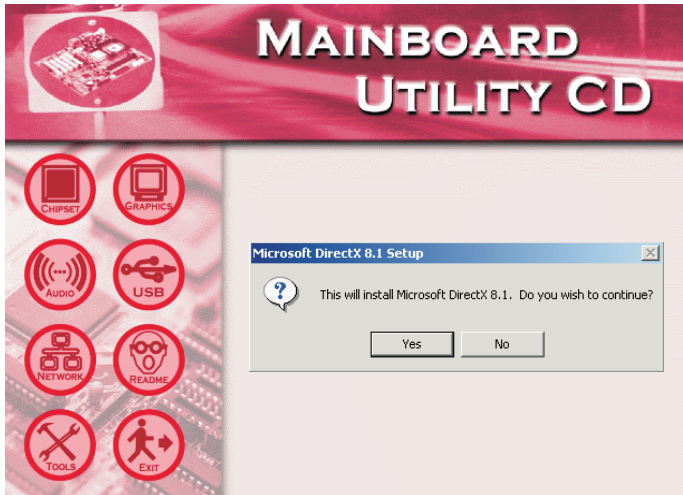

3. Click "Yes" to continue.
4. Follow the prompts on the screen to complete installation.
5. Restart the system.

### 4.2.7 McAfee VirusScan Online (English OS only)

The McAfee VirusScan Online is the most reliable and convenient way of protecting your PC from computer viruses. When you install McAfee VirusScan Online, your computer is safe because it automatically scans for viruses and checks for virus updates so that PC protection stays up-to-date.

To install, please follow the steps below.

1. On the left side of the autorun screen, click the "TOOLS" icon.
2. Click "McAfee VirusScan Online" on the main screen. The screen below will appear:



3. Click "Yes" to continue.
4. Follow the prompts on the screen to complete installation.
5. Restart the system.

### 4.3 Installation Notes

1. "Autorun" ONLY supports the Windows® 98, Windows® 98 SE, Windows® ME, Windows® 2000, Windows NT® 4.0 and Windows® XP operating systems. If after inserting the CD, "Autorun" did not automatically start (which is, the Main Board Utility CD screen did not appear), please go directly to the root directory of the CD and double-click "Setup".
2. All steps or procedures to install software drivers are subject to change without notice as the softwares are occasionally updated. Please go to DFI's web site at "<http://www.dfi.com/support1/download2.asp>" for the latest version of the drivers or software applications.

# Appendix A - Using the Suspend to RAM Function

## A.1 Using the Suspend to RAM Function

If you are using the Windows® 98 operating system, please follow the steps below.

1. Select "Power Management Setup" in the main menu screen and press <Enter>.
2. In the "ACPI Function" field, select "Enabled".
3. In the "ACPI Suspend Type" field, select "S3(STR)".

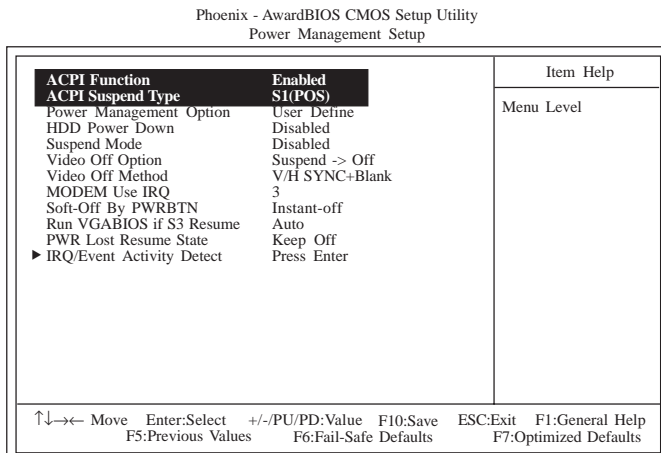

The settings on the screen are for reference only. Your version may not be identical to this one.

4. Press <Esc> to return to the main menu.
5. Select "Save & Exit Setup" and press <Enter>. Type <Y> and press <Enter>.
6. Install Windows® 98 by typing the following parameter. This is to ensure that the ACPI function is supported.

[drive]:>setup /p j

If you have previously installed Windows® 98, you need to upgrade the system in order to support ACPI. Please contact Microsoft for upgrade information.

## Using the Suspend to RAM Function .....

7. Boot Windows® 98. In the Windows® 98 desktop, click the Start button. Move the cursor to Settings, then click Control Panel.

To check whether ACPI was properly installed, double-click the System icon. In the System Properties dialog box, click the “Device Manager” tab. In “View devices by type”, click “System devices”.

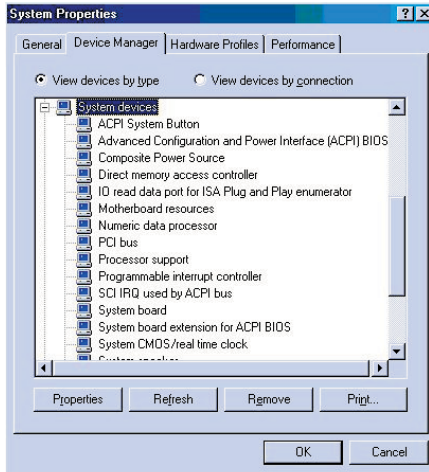

8. Double-click the System icon. In the System Properties dialog box, click the Performance tab.



## Using the Suspend to RAM Function

- Click File System. In the “Typical role of this computer” field, select “Mobile or docking system”. Click Apply, then click OK. Restart the computer:

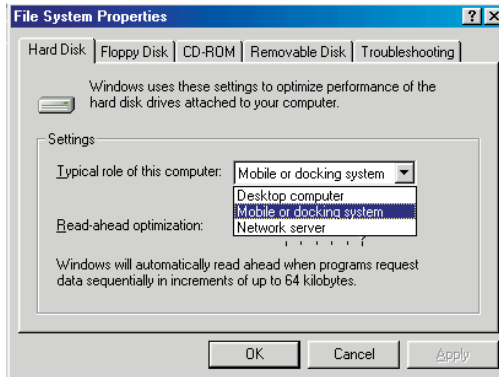

- Repeat step 7 to open the Control Panel dialog box. Double-click the Power Management icon.
- Click the Advanced tab. In the “When I press the power button on my computer” field, select “Standby”.

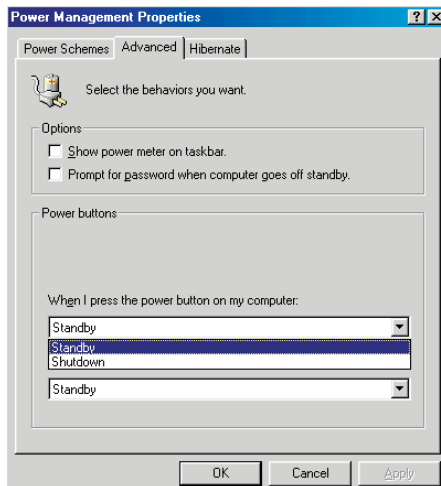

12. After completing the steps above and you want to power-off the computer; you do not need to go through the process of closing files, applications and operating system. You can power-off the computer at once by pressing the power button or selecting "Standby" when you shut down Windows® 98.

To power-on the computer; just press the power button. The operating session where you left off when you power-off the computer will resume in not more than 8 seconds.

If you have changed the color or resolution (in the Display Properties dialog box), do not apply the settings without restarting. You must restart the computer.

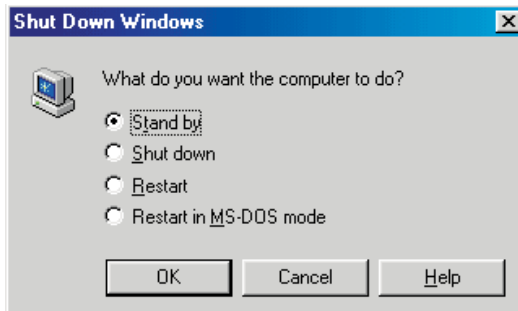

**Important:**

*If you are unable to use the Suspend to RAM function (after performing the steps above in Windows® 98 or when you are in Windows® 2000/ME/XP), please check whether your add-in cards or devices support this function. If this function is not supported, you need to download the appropriate driver from their respective website.*



## Appendix B - System Error Message

---

When the BIOS encounters an error that requires the user to correct something, either a beep code will sound or a message will be displayed in a box in the middle of the screen and the message, PRESS F1 TO CONTINUE, CTRL-ALT-ESC or DEL TO ENTER SETUP, will be shown in the information box at the bottom. Enter Setup to correct the error.

### B.1 POST Beep

There are two kinds of beep codes in the BIOS. One code indicates that a video error has occurred and the BIOS cannot initialize the video screen to display any additional information. This beep code consists of a single long beep followed by three short beeps. The other code indicates that a DRAM error has occurred. This beep code consists of a single long beep.

### B.2 Error Messages

One or more of the following messages may be displayed if the BIOS detects an error during the POST. This list indicates the error messages for all Awards BIOSes:

#### CMOS BATTERY HAS FAILED

The CMOS battery is no longer functional. It should be replaced.



**Caution:**

*Danger of explosion if battery incorrectly replaced. Replace only with the same or equivalent type recommended by the manufacturer. Dispose of used batteries according to the battery manufacturer's instructions.*

#### CMOS CHECKSUM ERROR

Checksum of CMOS is incorrect. This can indicate that CMOS has become corrupt. This error may have been caused by a weak battery. Check the battery and replace if necessary.

#### DISPLAY SWITCH IS SET INCORRECTLY

The display switch on the mainboard can be set to either monochrome or color. This indicates the switch is set to a different

setting than indicated in Setup. Determine which setting is correct, either turn off the system and change the jumper or enter Setup and change the VIDEO selection.

#### **FLOPPY DISK(S) fail (80)**

Unable to reset floppy subsystem.

#### **FLOPPY DISK(S) fail (40)**

Floppy type mismatch.

#### **Hard Disk(s) fail (80)**

HDD reset failed.

#### **Hard Disk(s) fail (40)**

HDD controller diagnostics failed.

#### **Hard Disk(s) fail (20)**

HDD initialization error.

#### **Hard Disk(s) fail (10)**

Unable to recalibrate fixed disk.

#### **Hard Disk(s) fail (08)**

Sector Verify failed.

#### **Keyboard is locked out - Unlock the key**

The BIOS detects that the keyboard is locked. Keyboard controller is pulled low.

#### **Keyboard error or no keyboard present**

Cannot initialize the keyboard. Make sure the keyboard is attached correctly and no keys are being pressed during the boot.

#### **Manufacturing POST loop**

System will repeat POST procedure infinitely while the keyboard controller is pull low. This is also used for the M/B burn in test at the factory.

#### **BIOS ROM checksum error - System halted**

The checksum of ROM address F0000H-FFFFFH is bad.

#### **Memory test fail**

The BIOS reports memory test fail if the memory has error(s).

## Appendix C - Troubleshooting

---

### C.1 Troubleshooting Checklist

This chapter of the manual is designed to help you with problems that you may encounter with your personal computer. To efficiently troubleshoot your system, treat each problem individually. This is to ensure an accurate diagnosis of the problem in case a problem has multiple causes.

Some of the most common things to check when you encounter problems while using your system are listed below.

1. The power switch of each peripheral device is turned on.
2. All cables and power cords are tightly connected.
3. The electrical outlet to which your peripheral devices are connected is working. Test the outlet by plugging in a lamp or other electrical device.
4. The monitor is turned on.
5. The display's brightness and contrast controls are adjusted properly.
6. All add-in boards in the expansion slots are seated securely.
7. Any add-in board you have installed is designed for your system and is set up correctly.

#### Monitor/Display

**If the display screen remains dark after the system is turned on:**

1. Make sure that the monitor's power switch is on.
2. Check that one end of the monitor's power cord is properly attached to the monitor and the other end is plugged into a working AC outlet. If necessary, try another outlet.
3. Check that the video input cable is properly attached to the monitor and the system's display adapter.
4. Adjust the brightness of the display by turning the monitor's brightness control knob.

### The picture seems to be constantly moving.

1. The monitor has lost its vertical sync. Adjust the monitor's vertical sync.
2. Move away any objects, such as another monitor or fan, that may be creating a magnetic field around the display.
3. Make sure your video card's output frequencies are supported by this monitor.

### The screen seems to be constantly wavering.

1. If the monitor is close to another monitor, the adjacent monitor may need to be turned off. Fluorescent lights adjacent to the monitor may also cause screen wavering.

## Power Supply

### When the computer is turned on, nothing happens.

1. Check that one end of the AC power cord is plugged into a live outlet and the other end properly plugged into the back of the system.
2. Make sure that the voltage selection switch on the back panel is set for the correct type of voltage you are using.
3. The power cord may have a "short" or "open". Inspect the cord and install a new one if necessary.

## Floppy Drive

### The computer cannot access the floppy drive.

1. The floppy diskette may not be formatted. Format the diskette and try again.
2. The diskette may be write-protected. Use a diskette that is not write-protected.
3. You may be writing to the wrong drive. Check the path statement to make sure you are writing to the targeted drive.
4. There is not enough space left on the diskette. Use another diskette with adequate storage space.

## Hard Drive

### Hard disk failure.

1. Make sure the correct drive type for the hard disk drive has been entered in the BIOS.
2. If the system is configured with two hard drives, make sure the bootable (first) hard drive is configured as Master and the second hard drive is configured as Slave. The master hard drive must have an active/bootable partition.

### Excessively long formatting period.

1. If your hard drive takes an excessively long period of time to format, it is likely a cable connection problem. However, if your hard drive has a large capacity, it will take a longer time to format.

## Parallel Port

### The parallel printer doesn't respond when you try to print.

1. Make sure that your printer is turned on and that the printer is on-line.
2. Make sure your software is configured for the right type of printer attached.
3. Verify that the onboard LPT port's I/O address and IRQ settings are configured correctly.
4. Verify that the attached device works by attaching it to a parallel port that is working and configured correctly. If it works, the printer can be assumed to be in good condition. If the printer remains inoperative, replace the printer cable and try again.

## Serial Port

The serial device (modem, printer) doesn't output anything or is outputting garbled characters.

1. Make sure that the serial device's power is turned on and that the device is on-line.
2. Verify that the device is plugged into the correct serial port on the rear of the computer:
3. Verify that the attached serial device works by attaching it to a serial port that is working and configured correctly. If the serial device does not work, either the cable or the serial device has a problem. If the serial device works, the problem may be due to the onboard I/O or the address setting.
4. Make sure the COM settings and I/O address are configured correctly.

## Keyboard

Nothing happens when a key on the keyboard was pressed.

1. Make sure the keyboard is properly connected.
2. Make sure there are no objects resting on the keyboard and that no keys are pressed during the booting process.

## Mainboard

1. Make sure the add-in card is seated securely in the expansion slot. If the add-in card is loose, power off the system, re-install the card and power up the system.
2. Check the jumper settings to ensure that the jumpers are properly set.
3. Verify that all memory modules are seated securely into the memory sockets.
4. Make sure the memory modules are in the correct locations.
5. If the board fails to function, place the board on a flat surface and seat all socketed components. Gently press each component into the socket.
6. If you made changes to the BIOS settings, re-enter setup and load the BIOS defaults.